



# FIREYE MODULAR M-SERIES II

## FLAME SAFEGUARD CONTROLS



**WARNING:** Selection of this control for a particular application should be made by a competent professional, licensed by a state or other government agency. Inappropriate application of this product could result in an unsafe condition hazardous to life and property.

### DESCRIPTION

Fireye® Modular M-Series II Flame Safeguard Controls are compact, modular burner management systems for intermittent operation. They are designed to provide automatic ignition and continuous flame monitoring for commercial sizes of heating and process burners that use gas and/or light oil fuels.

Flame monitoring is accomplished by miniature UV scanners or Flame Rod detectors and plug-in amplifier and programmer modules which connect into a standard chassis and wiring base. Interchangeable programmer and amplifier modules allow for complete versatility in selection of control function, timing, and flame scanning means. Functions such as re-ignition or non-recycle are determined by the programmer module. Type of flame scanner (UV or Flame Rod) and Flame Failure Response Time (F.F.R.T.) are determined by the amplifier module.

LED indicator lights on all programmer modules indicate the operating status of the control.

In the event of ignition failure, or following a safety shutdown, the unit locks out, activating an alarm circuit. Manual reset is required. Remote reset (via remote pushbutton or power interruption) is available on the MC120RE and MC230R chassis. A detailed description of the various programmer modules is found later in this document. Test jacks are provided to permit flame signal measurement during operation.

Modular M-Series II controls incorporate a safety checking circuit that is operative on each start. If flame (real or simulated) is detected prior to a start or during the purge, the fuel valves will not be energized, and the unit will lock out.

The Modular M-Series II controls use the same wiring base as the Fireye UVM and TFM Controls and are designed to be interchangeable with most models without rewiring. See **INSTALLATION OF CONTROL, SCANNERS, AND FLAME DETECTORS** for temperature and wiring requirements.



## SPECIFICATIONS

### Supply:

120 V (min. 102, max. 132) 50/60 Hz. (MC120E and MC120RE)

230V (min. 196, max 253) 50/60Hz (MC230 and MC230R)

**Table 1: AMBIENT TEMPERATURE LIMITS**

	MAXIMUM		MINIMUM	
	°F	°C	°F	°C
Control	140	(60)	- 40	(- 40)
Scanner UV1A, UV2, UV8A, 45UV3	200	(93)	- 40	(- 40)
Flame Rod (Tip 2460 F)	1500	(816)	- 40	(- 40)

### Power Consumption:

12 VA (Operating)

### Shipping Weight (Approx.):

5 lbs. (2.3 Kg.)

**Table 2: LOAD RATINGS (15 Amps circuit breaker\* connected in series between terminal 1 and 7).**

Fireye Terminal	Typical Load	Maximum Rating & 120V 50/60 Hz or 230V 50/60 Hz.
3 or 4 Individual or combined	Pilot valve(s) Solenoid valve Ignition Transformer	125 VA pilot duty (solenoid valve) plus 250 VA (Transformer)
5	Main Fuel Valve(s)	125 VA pilot duty (solenoid) or 25 VA pilot duty (solenoid) and 400 VA (opening) motorized
8	Motor or contactor	Motor normally energized and de-energized by the operating control whose rating must be suitable. Terminal 8, for the 120V series products, is rated to de-energize 9.8 FLA, 58.8 LRA, on safety lockout, for the 230V series products, is rated to de-energize 5.2 FLA, 31.2 A LRA, on safety lockout.
A	Alarm	50 VA, pilot duty

\* Circuit breaker, type standard delay suggested Potter & Brumfield.

#W67-X2Q12-15V or equivalent.

Specification: Single pole, series trip, white toggle.

Max. Line voltage 250 VAC 50/60 Hz.

Current rating 15 Amps.

VDE approved breaker 0642/EN60934.

Insulation resistance: 100 Megohms at 500VDC.

Operating Temperature: -40°C to 85°C.

## OUTLINE DIMENSIONS

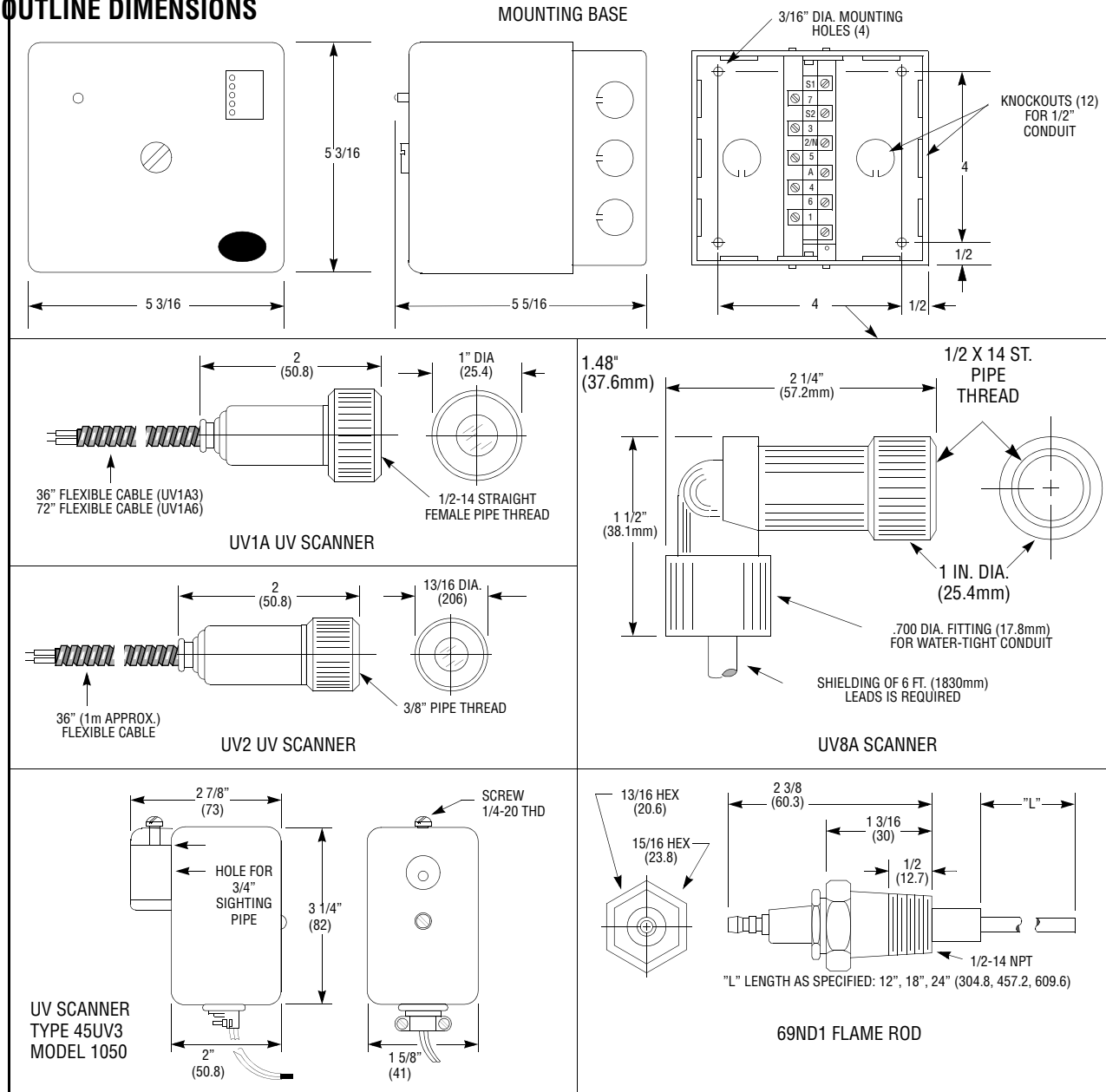

## ORDERING INFORMATION

### CHASSIS (COMMON FOR ALL CONTROLS, INCLUDES DUST COVER):

MC120E 120 VAC Supply, 50 Hz/60 Hz

MC120RE 120 VAC supply, 50 Hz/60 Hz. Remote reset capability.

MC230 230 VAC Supply, 50 Hz/60 Hz

MC230R 230 VAC Supply, 50 Hz/60Hz. Remote reset capability.

### PROGRAMMER MODULES:

MP100, MP100E Re-ignition operation, 10 second ignition safety time.

MP102, MP102E Non-Recycle operation, 5 second ignition safety time.

*NOTE: Programmers with the suffix "E" (e.g. MP100E) are for use with the MC230 and MC230R Chassis only.*



<b>AMPLIFIER MODULES:</b>	<b>USE WITH SCANNERS:</b>
MAUV3 UV amplifier, 3 second F.F.R.T.	UV1A, UV2, UV8A, 45UV3-1050
MAUVIT UV amplifier, 1 second F.F.R.T.	UV1A, UV2, UV8A, 45UV3-1050
MART3 Flame rectification amplifier, 3 second F.F.R.T.	69ND1
MART1T Flame rectification amplifier, 1 second F.F.R.T.	69ND1

**UV SCANNERS:**

UV1A3	1/2" NPT connector, 3' (914mm) flex. cable
UV1A6	1/2" NPT connector, 6' (1829mm) flex. cable
UV2	3/8" NPT connector, 3' (914mm) flex. cable
UV8A	1/2" NPT 90 degree angle head, 6' (1829mm) flex. cable
45UV3-1050	3/4" sleeve/setscrew mount

**FLAME DETECTORS:**

69ND1-1000K4	12 inch (304.8mm) flame rod, 1/2" NPT connector
69ND1-1000K6	18 inch (457.2mm) flame rod, 1/2" NPT connector
69ND1-1000K8	24 inch (609.6mm) flame rod, 1/2" NPT connector

**WIRING BASE (COMMON FOR ALL CONTROLS):**

- 61-3060 Closed wiring base, surface mounting
  - 61-5042 Open wiring base, cabinet mounting
- For a complete system, choose one of each of the following:
- Chassis — UV Scanner or Flame Detector
  - Programmer Module — Wiring Base
  - Amplifier Module



**WARNING: Installer must be trained and qualified. Follow the burner manufacturer's instructions, if supplied. Otherwise, proceed as follows:**

---

## INSTALLATION OF CONTROL, SCANNERS, AND FLAME DETECTORS

### Wiring Base

Mount the wiring base on the burner or on a panel. The location should be free from excessive vibration and within the specified ambient temperature rating. The base may be mounted in any angular position.

All wiring should comply with applicable electrical codes, regulations, and local ordinances. Use moisture resistant wire suitable for at least 90 degrees C. Circuit recommendations are found on Pages 14 through 15. Consult the factory for assistance with non-standard applications.



**WARNING: Controls require safety limits utilizing isolated mechanical contacts. Solid state limit switches are not acceptable and should not be used due to their high leakage currents.**

### Installing the Programmer and Amplifier Modules



**WARNING: Remove power from the control before proceeding.**

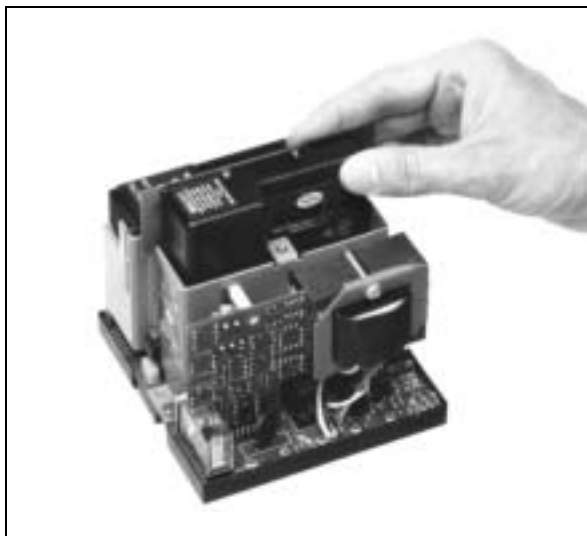

AMPLIFIER

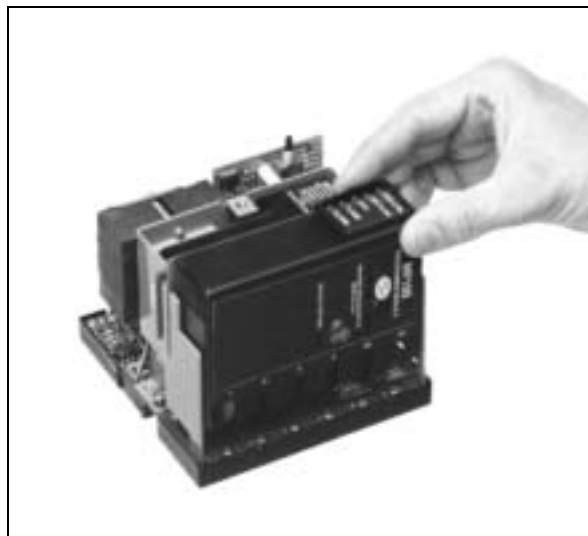

PROGRAMMER

Select the appropriate programmer and amplifier modules for your application. Remove the dust cover from the chassis. Insert the amplifier module into the slot in the center of the chassis and gently push the module into position. Insert the programmer module into the slot at the right side of the chassis and gently push the module into position.



**WARNING: Turn off the power when installing or removing the control.**

## INSTALLATION - UV SCANNERS

Where possible, obtain the burner manufacturer's instructions for mounting the scanner. This information is available for most standard burners. The scanner mounting should comply with the following general instructions:

1. Locate the scanner within 30 inches (76cm) of the flame to be monitored, closer if possible.
2. Select a scanner location that will remain within the ambient temperature limits of the UV-eye scanner (200°F/93°C). If cooling is required, use (a) an insulating coupling (Fireye part #35-69) to reduce conducted heat; (b) a window coupling (Fireye part #60-1257) to seal off furnace or burner pressure; (c) cooling air to reduce the scanner sight pipe temperature.
3. Mount rigidly a short length (10-20cm) of  $\frac{1}{2}$ " or  $\frac{3}{4}$ " black iron pipe in a position that permits an unobstructed view of the pilot and/or main flame.



**CAUTION: The scanner must not sight the ignition spark directly, or any part of the burner that can reflect the spark back to the scanner.**

4. The maximum UV signal from a flame is found in the first one-third of the visible flame taken from the point where the flame begins. The scanner sight pipe should be aimed at this area.
5. A correct scanner application will not see a pilot flame that is too small to ignite the main flame reliably. Note particularly the test for minimum pilot that is described on Page 12.
6. On installations having negative pressure combustion chambers, a small hole ( $\frac{1}{8}$ " or  $\frac{3}{16}$ " (3 or 5mm) drilled in the sight pipe will assist in keeping the pipe clean and free from smoke.
7. Two scanners may be installed on one burner if it is necessary to view two areas to obtain reliable detection of the flame. They should be wired in parallel.

8. The UV-eye scanner is designed to seal off the sight pipe up to pressures of 1 PSI (.07kg/cm<sup>2</sup>) when the scanner lock nut is firmly tightened. Pressures in excess of 1 PSI (.07kg/cm<sup>2</sup>) should be blocked from the scanner. A quartz lens coupling (Part #60-1290) or quartz window coupling (Part #60-1257) may be used. Each is rated from -3 to +100 PSI max. (-.2kg/cm<sup>2</sup> to +7kg/cm<sup>2</sup> max.).
9. To increase scanner sensitivity, a quartz lens coupling (Part #60-1290) may be used. The quartz lens permits location of the UV-eye twice the distance noted in Item 1. Use 1/2" x 1 1/2" whipple between UV1A scanner and union. Use 3/8" close nipple and 1/2" by 3/8" bushing on UV-2 applications.

### General Requirements

1. As close as possible — 30" (76cm) or closer.
2. As cool as possible — Not over 200°F/93°C.
3. Avoid sighting the spark — Resight scanner, shield between spark and scanner, or orifice to reduce reflected signal from spark.
4. Must see pilot and/or main flame — Scanner view must be unobstructed,
5. Minimum pilot test — See Page 12.

### Typical Scanner Installations

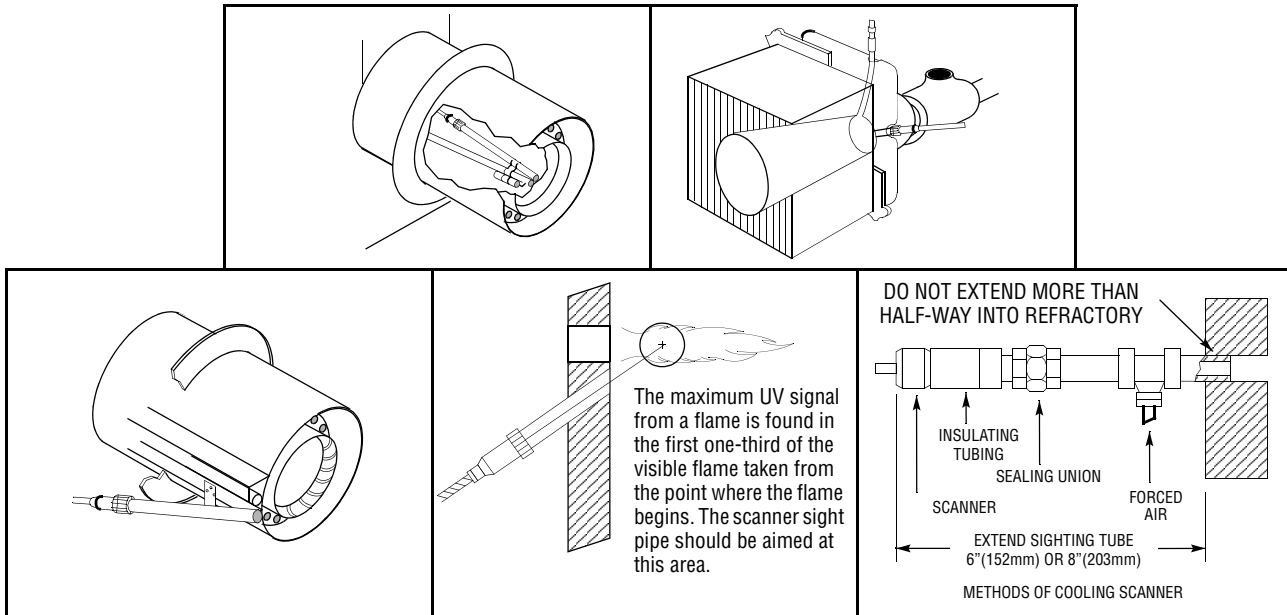

### Wiring of UV Scanners

The UV1A scanner is supplied with 3' (90cm) or 6' (180cm) of flexible cable. The UV-2 scanner is supplied with 3' (90cm) of flexible cable. If it is necessary to extend the scanner leads, the following instructions apply:

1. Scanners without armored cable must be wired using metal cable or rigid conduit.
2. High voltage wiring must not be installed in the same conduit with flame detector wiring.
3. **Selection of Scanner Wire:**
  - a. Use #14, 16, or 18 gauge wire with 90°C, 600 volt insulation for up to 200 feet (60M) of distance. (approx. 20% signal loss at 100 feet [30M], 40% signal loss at 200 feet [60M]).
  - b. Asbestos insulated wire should not be used.
  - c. Multi-conductor cable is not recommended without prior factory approval.
  - d. High voltage ignition wiring *should not* be installed in the same conduit with flame detector wires.

**4. Installation of Extended Scanner Wiring:**

- For extended scanner wiring up to 500 feet (150M), and for shorter lengths to reduce signal loss, use a shielded wire (Belden 8254-RG62 coaxial cable, or equal) **for each scanner wire** of UV1, UV2. The ends of the shielding must be taped and not grounded.

**5. Multiple Scanner Installations:**

- The wiring from multiple UV scanners may be installed in a common metallic conduit.
- Multi-conductor cable is not recommended without prior factory approval.

**INSTALLATION - 69ND1 FLAME ROD**

The 69ND1 flame rod proves a gas pilot flame and/or main gas flame. It is a *spark plug* type unit consisting of 1/2" NPT mount, a KANTHAL flame rod, a glazed porcelain insulating rod holder and a spark plug connector for making electrical connections. The 69ND1 is available in 12" (304.8mm), 18" (457.2mm) or 24" (609.2mm) lengths.

The flame rod may be located to monitor only the gas pilot flame or both the gas pilot and main gas flames. It is mounted on a 1/2" NPT coupling.

The following instructions should be observed:

1. Keep flame rod as short as possible.
2. Keep flame rod at least 1/2" (12.7mm) from any refractory.
3. Flame rod should enter the pilot flame from the side so as to safely prove an adequate pilot flame under all draft conditions.
4. If the flame is nonluminous (air and gas mixed before burning), the electrode tip should extend at least 1/2" (12.7mm) into the flame, but not more than halfway through

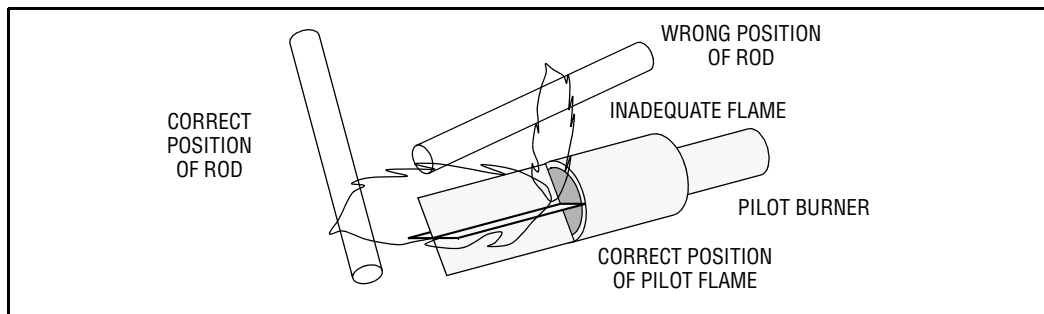

5. If the flame is partly luminous, the electrode tip should extend only to the edge of the flame. It is not necessary to maintain absolutely uninterrupted contact with the flame.
6. It is preferable to angle the rod downward to minimize the effect of sagging and to prevent it from coming in contact with any object.
7. An adequate grounding surface for the flame must be provided. The grounding surface in actual contact with the flame must be at least four times greater than the area of the portion of the flame rod in contact with the flame. It is essential to adjust the flame rod and ground area ratio to provide a minimum signal reading of 6VDC.

*Note: Interference from the ignition spark can alter the true signal reading by adding to, or subtracting from it. This trend sometimes may be reversed by interchanging the primary wires (line voltage) to the ignition transformer. This interference can also be reduced by the addition of grounded shielding between the flame rod and ignition spark.*

8. Proven types of flame grounding adapters, as shown below, may be used to provide adequate grounding surface. High temperature stainless steel should be used to minimize the effect of metal oxidation. This assembly may be welded directly over the pilot or main burner nozzle

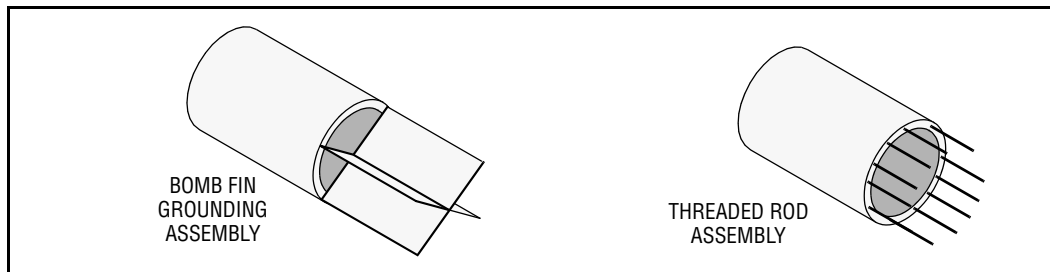

## WIRING OF FLAME RODS

For proper operation of flame rectification systems (flame rods), it is necessary to maintain at least 20 megohms insulating resistance in the flame rectification circuit.

1. The scanner should be wired using metal cable or rigid conduit.
2. High voltage wiring must not be installed in the same conduit with scanner wiring.

### Selection of Scanner Wire

1. Use #14, 16, or 18 gauge wire with 90°C, 600 volt insulation for up to 100 feet (30M) distance.
2. The type of insulation used with flame rectification wiring is important, since it must protect against current leakage resistance to ground. Use Belden 8254-RG62 Coaxial Cable (or equal) for runs greater than 100 feet (30M). **Maximum wiring run not to exceed 400 feet (120M).**

## MAINTENANCE

### Type UV1, UV2, UV8A, and 45UV3 Ultraviolet Scanners

The viewing area of the scanner must be kept clean. Even a small amount of contamination will reduce the flame signal reaching the detector by a measurable amount. Wipe the viewing area routinely using a soft cloth dampened with concentrated detergent.

### Type 69ND1 Flame Rod

The flame rod and its insulator should be kept clean by washing routinely with soap and water. Rods should be routinely replaced as they oxidize.

### Flame Signal Strength

Routine observation of the flame signal strength will forewarn any deterioration in the capability of the flame detector or its application.

### Periodic Safety Check

It is recommended that a procedure be established to test the complete flame safeguard system at least once a month. This test should verify the proper operation of all limit switches and safety interlocks as well as flame failure protection and fuel safety shutoff valve tightness.

### Rotation

It is recommended that control and scanner units purchased as spares be installed periodically.

---

## MC120E REMOTE RESET CHASSIS

The MC120RE and MC230R Chassis provides remote reset capabilities in the event of a lockout condition. The remote reset chassis can be reset in any of the following ways:

1. Depress and release the reset button built into the chassis. This reset button will always reset the control.
2. To reset the control via a remote pushbutton. Wire a momentary dry contact pushbutton into the two (2) terminals located on the chassis (on the same PC board as the built-in reset switch) and depress the button for one (1) second. The maximum distance the remote reset switch can be wired from the control is 1,000 feet (300M).



**CAUTION: Remote reset is recommended only on a control solely for proved ignition programming (pilot ignited burner) or a control for use only with appliances in which unburned fuel cannot accumulate and that is intended for installation in inaccessible locations such as open-flame, ceiling-suspended gas heaters.**

---

## LED INDICATOR LIGHTS

The Programmer Modules have 5 LED lights to indicate the operating status of the control. The function of these lights are:

**Operating Control:** This LED is energized whenever the burner control switch (Terminal #7) along with the various limit switches, operating controls and fuel interlocks are closed.

**Air Flow:** This LED is energized whenever the air flow switch is closed between Terminals #8 and #6, and power is on Terminal #8.

**PTFI:** This LED is energized only during the Ignition Safety Time.

**Flame On:** This LED is energized whenever a flame signal is detected by the UV scanner or Flame detector.

**Alarm:** this LED is energized whenever a safety lockout occurs. (See APPLICATION AND FUNCTION section).

---

## APPLICATION AND FUNCTION - MP100, MP100E

The MP100 and MP100E Programmer Modules are designed as a replacement for the Fireye M1 Series “re-ignition” controls. It provides ignition and Flame Safeguard for heating or process light oil or gas fired burners. The Amplifier Module should be selected based on the type of flame scanner (UV scanner, or flame rod), and the required Flame Failure Response Time (F.F.R.T.). See ORDERING INFORMATION on Page 4 for the appropriate part numbers.

### Pilot Ignited Burners

The typical wiring arrangement illustrated on Page 16 for pilot ignited burners provides the following function:

1. With power applied, and the limit-operating control circuit closed (**Operating Control LED** lit), the burner motor circuit is energized. The air flow switch circuit closes (**Air Flow LED** lit).
2. Following a short-time delay (4 to 6 sec.), KL-1 closes, energizing Terminal 3 which powers the pilot gas valve, and Terminal 4 which powers the spark ignition. A 10 sec. trial for ignition is initiated (**PTFI LED** lit).
3. When pilot flame is detected (**Flame LED** lit), KF-1 closes, energizing Terminal 5 which powers the main fuel valve, and KF-2 opens, de-energizing Terminal 4 which shuts off the spark ignition.
4. When the operating control opens its circuit, or if a power failure occurs, the control is de-energized. When power is restored, the control will restart.



*NOTE: Controls with UV amplifiers (MAUV3 and MAUVIT) are always powered via Terminal #1.*

5. In the event the pilot flame is not detected by the end of the trial for ignition period, the pilot gas valve and spark ignition are de-energized. A safety lockout occurs which de-energizes the burner motor and energizes the lockout alarm circuit (**Alarm LED lit**) approximately 10 to 30 seconds after the safety shutdown occurs.
6. In the event of a flame failure during a firing period, the main fuel valve is de-energized and the spark ignition re-energized. A 10 sec. trial for ignition is initiated (**PTFI LED lit**). If flame is detected (**Flame LED lit**) during the trial for ignition period, the main fuel valve is re-energized and the spark ignition de-energized. If flame is not detected during the trial for ignition period, the pilot gas valve and spark ignition are de-energized. A safety lockout occurs which de-energizes the burner motor and energizes the lockout alarm circuit (**Alarm LED lit**) approximately 10 seconds after the safety shutdown occurs.
7. **Manual reset is required following any safety lockout.**

*NOTE: Wait 10 seconds after lockout before resetting the control.*

### **Direct Spark Ignited Burners**

The typical wiring arrangement illustrated on Page 16 for direct spark ignited burners provides the following function:

1. With power applied, and the limit-operating control circuit closed (**Operating Control LED lit**), the burner motor circuit is energized. The air flow switch circuit closes (**Air Flow LED lit**).
2. Following a short-time delay (4-6 sec.) KL-1 closes, energizing Terminal 3 which powers the primary main fuel valve and Terminal 4 which powers the spark ignition. A 10 sec. Trial for ignition is initiated (**PTFI LED lit**).
3. When main flame is detected (**Flame LED lit**), KF-1 closes, energizing Terminal 5 which powers the secondary main fuel valve (if used), KF-2 opens de-energizing Terminal 4 which shuts off the spark ignition.
4. When the operating control opens or if a power failure occurs, the control is de-energized. When power is restored, the control will restart.

*NOTE: Controls with UV amplifiers (MAUV3 and MAUVIT) are always powered via Terminal #1.*

5. In the event that main flame is not detected by the end of the trial for ignition period, the primary main fuel valve and the spark ignition are de-energized. A safety lockout occurs which de-energizes the burner motor and energizes the lockout alarm circuit (**Alarm LED lit**) approximately 10 to 30 seconds after the safety shutdown occurs.
6. In the event of a flame failure during a firing period, the secondary main fuel valve (if used) is de-energized and the spark ignition is re-energized. A 10 sec. trial for ignition is initiated (**PTFI LED lit**). If flame is detected (**Flame LED lit**), the secondary main fuel valve (if used) is re-energized and the spark ignition de-energized. If flame is not detected during the trial for ignition period, the primary main fuel valve and the spark ignition are de-energized. A safety lockout occurs, which de-energizes the burner motor and energizes the lockout alarm circuit (**Alarm LED lit**) approximately 10 to 30 seconds after the safety shutdown occurs.
7. **Manual reset is required following and safety lockout.**

*NOTE: Wait 10 seconds after lockout before resetting the control.*

---

## **APPLICATION AND FUNCTION - MP102 and MP102E**

The MP102 and MP102E operates in the same manner as the MP100 and MP100E with the following exceptions. The standing pilot and re-ignition features have been eliminated. The ignition safety time has been changed to 5 seconds and the control will lockout on flame failure.

## INSTALLATION TESTING

### Use of Test Meter (All Controls)

Testing the Fireye Modular M-Series II Controls requires the use of a test AC-DC multimeter, with a 1,000 ohm/volt DC rating or greater, or a digital meter with 500K input impedance or greater.

With the test meter on the DC scale, and the test meter leads inserted into the test jacks on the amplifier module, a **steady DC voltage reading of 4.0 to 6.0 volts (for UV amplifiers) and 6 to 18 volts (for flame rectification amplifiers)** should be obtained when the controls are detecting flame, and zero volts when no flame is present.

With the test meter on the AC scale, line and load voltages may be measured at the identified test points on the chassis.

On the Modular M-Series II controls utilizing a flame rectification amplifier, a micro-ammeter may be connected in series with the wire to Terminal S2. Normal flame will produce a meter reading between 4 and 10 micro-amps.

### Flame Signal Testing (All Controls)

1. Manually shut off the main fuel valve for a pilot ignited burner, or the secondary fuel valve for a direct spark ignited burner.
2. Set the test meter on the DC scale and insert the test leads into the test jacks on the amplifier module. (If the meter reads backwards, reverse the meter leads). Red - Plus, Black - Negative.
3. Initiate a normal startup.
4. When flame is established, the test reading should be normal: a steady DC voltage reading of 4.0 to 6.0 volts (for UV amplifiers) and 6 to 18 volts (for flame rectification amplifiers).
5. Inadequate flame signal may be improved by:
  - a. Assuring that the flame detector and wiring installations have followed the instructions on Pages 5 through 9.
  - b. Assuring that the flame detector is clean and within the ambient temperature limits.
  - c. Assuring that the flame is sufficiently large to detect.
  - d. Assuring that the flame quality (fuel to air ratio, combustion air velocity) is satisfactory.
  - e. Trying a shorter sight pipe, or increasing the sight pipe diameter.



**WARNING: Before making a pilot flame test, manually shut off the fuel supply to the main burner.**

### Normal Pilot Flame Test

1. Turn power on and initiate a normal startup.
2. Observe the pilot flame signal on the test meter. If the average flame is below normal, a steady DC voltage reading of 4.0 to 6.0 volts (for UV amplifiers) and 6 to 18 volts (for flame rectification amplifiers), re-adjust the pilot flame or realign the flame detector.



**WARNING: DO NOT TOUCH a flame rectification rod with power applied**

3. During the pilot flame test and adjustment period, if flame is not detected within 10 seconds, the control will lock out. To reestablish the pilot flame trial for ignition (P.T.F.I.), manual reset of the lockout switch is required, and a complete repurge is accomplished.
4. When UV detection is used, a test is required to verify that UV radiation from the ignition spark is not being detected. To accomplish this, manually shut off both pilot and main fuels. Initiate a normal startup, observe the test meter which should read no more than 1/2 volt DC. If more than 1/2 volt DC is observed, realign the UV scanner, and/or shield the spark from the scanner's view.



**WARNING: The minimum pilot test must be accomplished by a trained and qualified burner technician.**

### Minimum Pilot Test

This test insures that the flame detector will not sense a pilot flame too small to light the main flame reliably. It must be made on every new installation as well as following the repositioning of the flame detector. **This procedure should not be used on a direct spark ignited burner.**

1. Manually shut off the fuel to the main burner.
2. Connect a test meter to the test jacks on the Amplifier Module.
3. Initiate a normal startup.
4. Reduce the fuel to the pilot until the DC voltmeter reads 3.5 volts for UV scanners. See WARNING below. This is the minimum pilot. For flame rectification the flame signal for minimum pilot varies depending on the application. See WARNING below.
5. Slowly turn on the main fuel and insure that the main flame lights off promptly and normally.



**WARNING: If light off is delayed, shut off the power to the installation. Realign the flame detector so that pilot flame detection requires a larger pilot flame. Repeat this test until the main flame lights reliably with minimum pilot.**

6. After the minimum pilot test is completed satisfactorily, increase the pilot flame to normal size, and observe that the main flame is properly established during a normal cycle.

### Flame Failure Test

1. Temporarily connect spark ignition and pilot valve to Terminal #3.
2. Initiate a normal startup.
3. Manually shut off all fuel and observe the loss of flame signal on the test meter.
4. If flame signal does not reduce to zero within the flame failure response time of the control (F.F.R.T. determined by selection of amplifier), verify that the UV flame detector is not actuated by the spark. If spark is detected, a metallic shield or relocation of the UV detector sight pipe is required.
5. **IMPORTANT:** When the test is completed, reconnect the spark ignition to Terminal #4.

### Recommendation

**Periodic Safety Check:** Test the complete flame safeguard system at least once a month. This test should verify flame failure safety shutdown and positive fuel cutoff when the fuel valve is de-energized.

### Replaceable Fuse

The programmer modules are designed with a field replaceable fuse. The fuse is located on the printed circuit board near the connectors. In the event the fuse becomes shorted, the Operating Control, Air Flow, and PTFI LED's will light. However, KL or KF (see WIRING ARRANGEMENTS - later in this document) will not be energized and the control will lock out. The fuse will blow as a result of an overload condition on Terminals 3, 4, or 5. To replace the fuse, remove the fuse (using a small screwdriver) and install a Fireye replacement fuse (P/N 23-176) or equivalent 2AG, 8 amp fuse Type Fast-Acting (e.g. Little Fuse #225008).

Order Fireye replacement fuse P/N 23-183 or equivalent (3.5 amp fuse 2AG Type SLO-BLO) for programmer modules used with the MC230 and MC230R chassis (e.g. Little Fuse #22903.5).



---

## MAINTENANCE

**UV-eye scanner:** The UV tube must be kept clean. Use a clean cloth with detergent as often as operating conditions require. Remove any residual detergent.

---

## ROTATION

It is recommended that units purchased as spares be rotated periodically, so that each unit will be placed in operation every 90 days.

# Microm SERVICE GUIDE

## SITUATION #1 NORMAL LOCKOUT

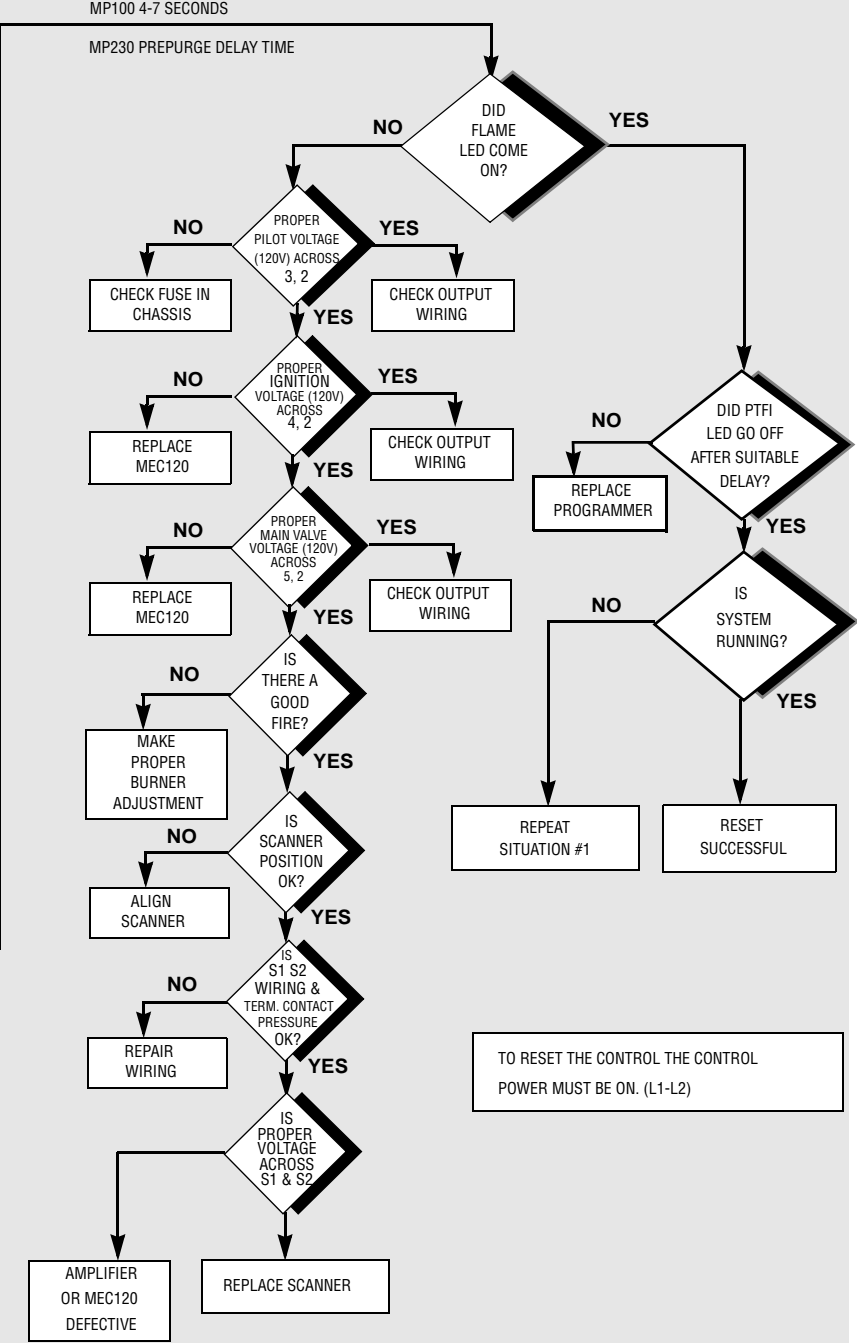
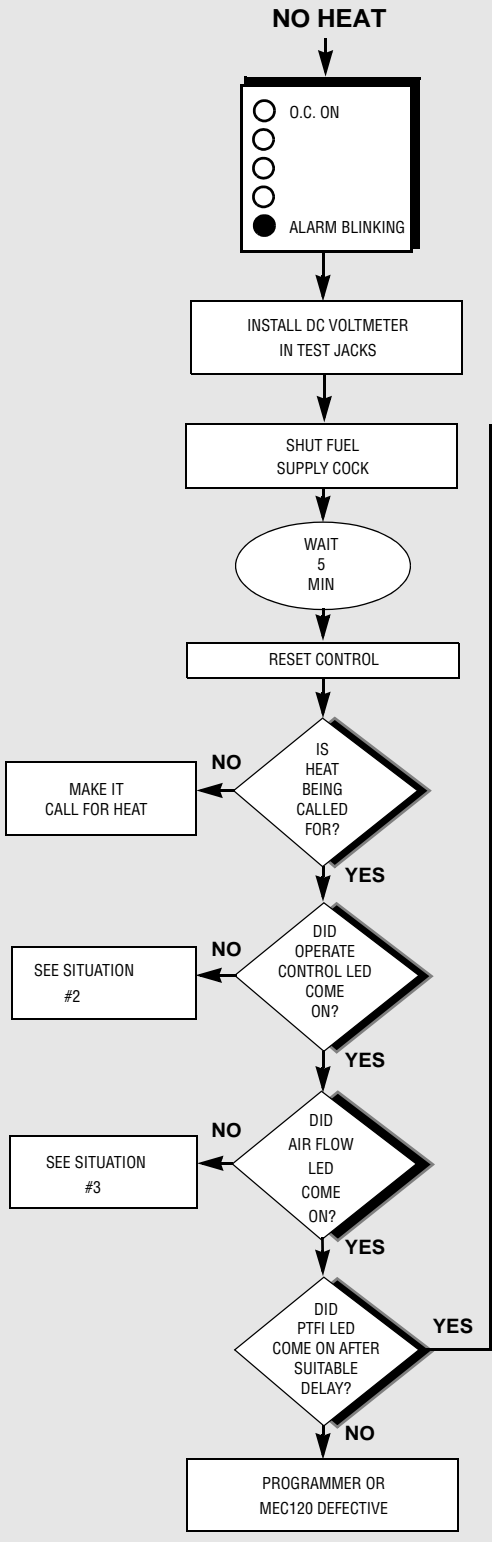
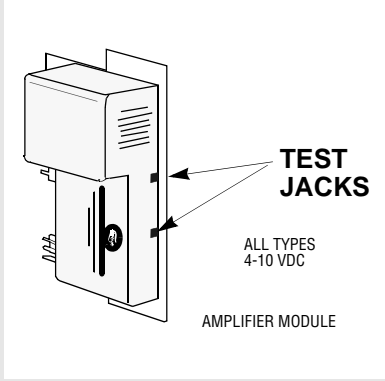

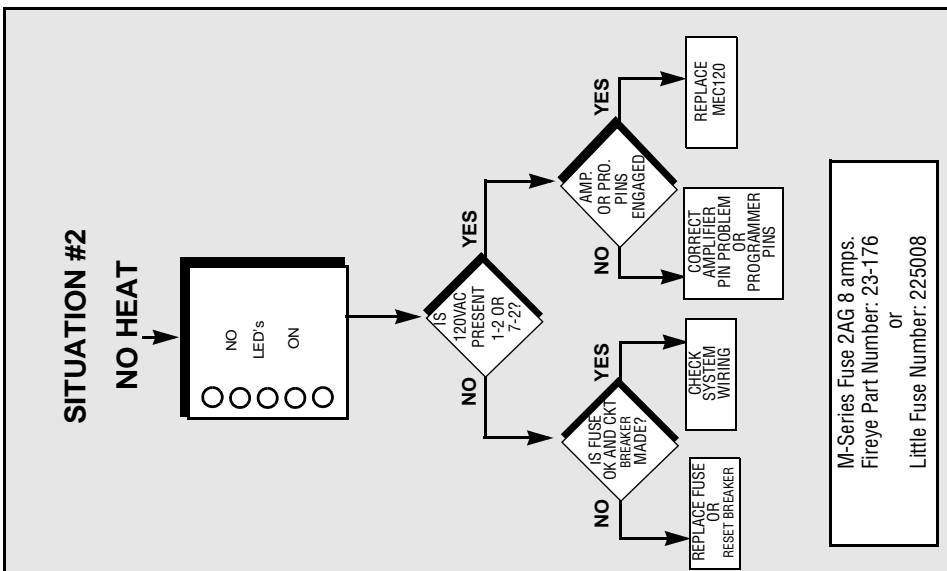
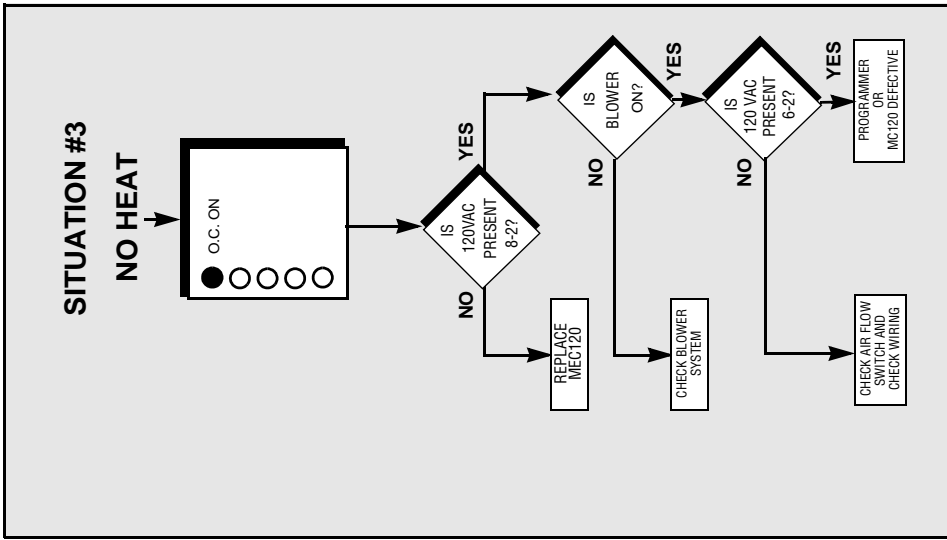
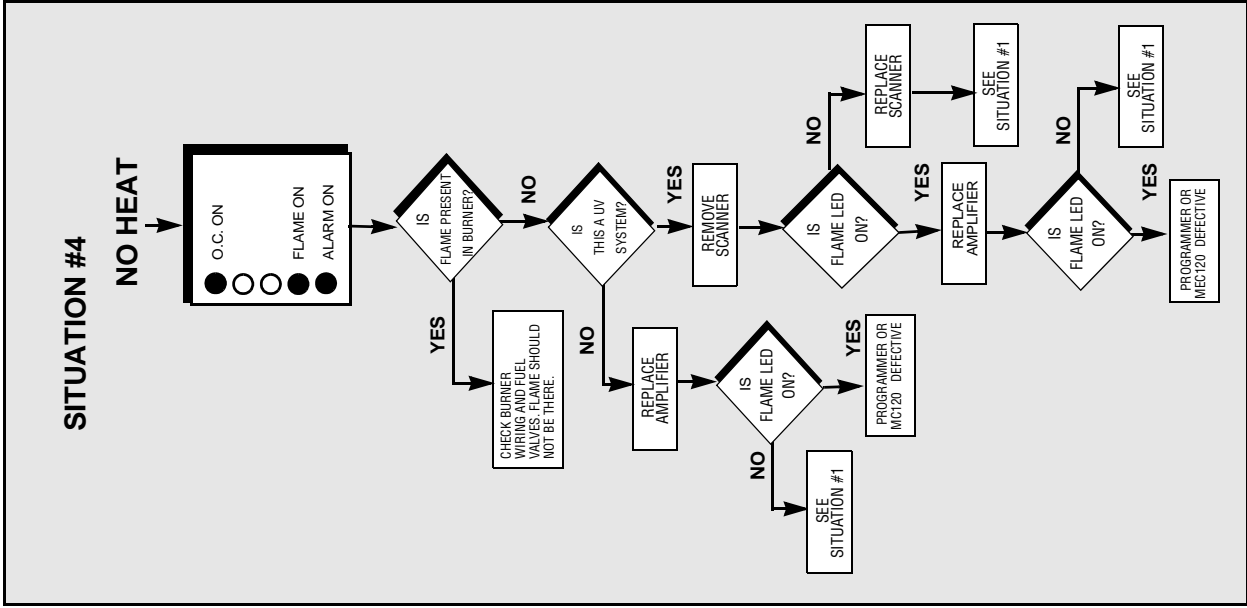

#### TROUBLESHOOTING TIPS

1. Verify that there is a solid earth ground wire brought to the panel that the Fireye base is mounted to.
2. In a rectification system, verify that terminal S1 is solidly earth grounded, and confirm that the flame rod is aligned so it doesn't droop near the ignition spark.
3. Confirm that there is no measurable voltage present between the ground screw and terminal 2 (neutral).
4. Confirm that the 120 volt AC supply has its neutral leg earth grounded at the supply, (floating isolation transformers can cause problems).
5. Confirm that the ignition transformer's secondary winding is solidly earth grounded. The grounding method is usually through the transformer case. Dirt, paint, loose mounting hardware, etc., can all be factors.
6. There may be a problem with transients in the main power supply. If you think this may be the problem, you may want to run a ground wire directly from the pilot assembly back to the electrical panel where the Fireye control is mounted.

**FIGURE 1.** TYPICAL MP100, MP100E, MP102, and MP102E WIRING ARRANGEMENT FOR PILOT IGNITED BURNER

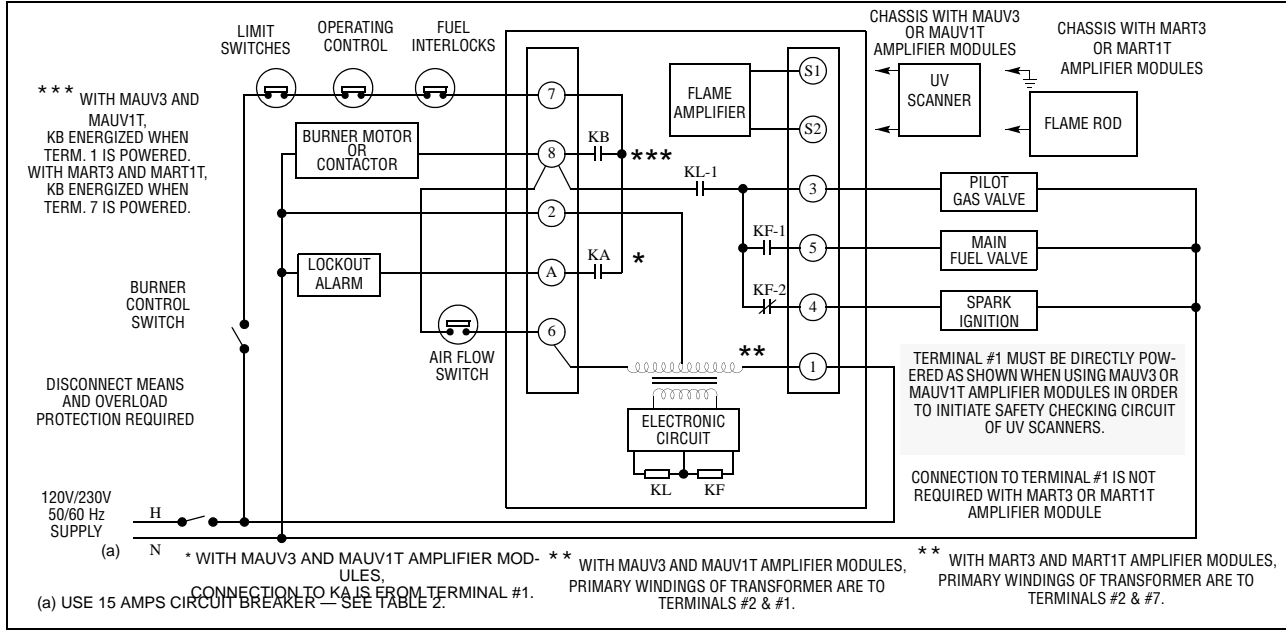

Use moisture resistant wire suitable for at least 90°C.



**CAUTION:** When powered, 560 VAC across S1, S2 with MAUV3 and MAUV1T; 260 VAC across S1, S2 with MART3 and MART1T.

**FIGURE 2.** TYPICAL MP100, MP100E, MP102, and MP102E WIRING ARRANGEMENT FOR DIRECT SPARK IGNITED BURNER

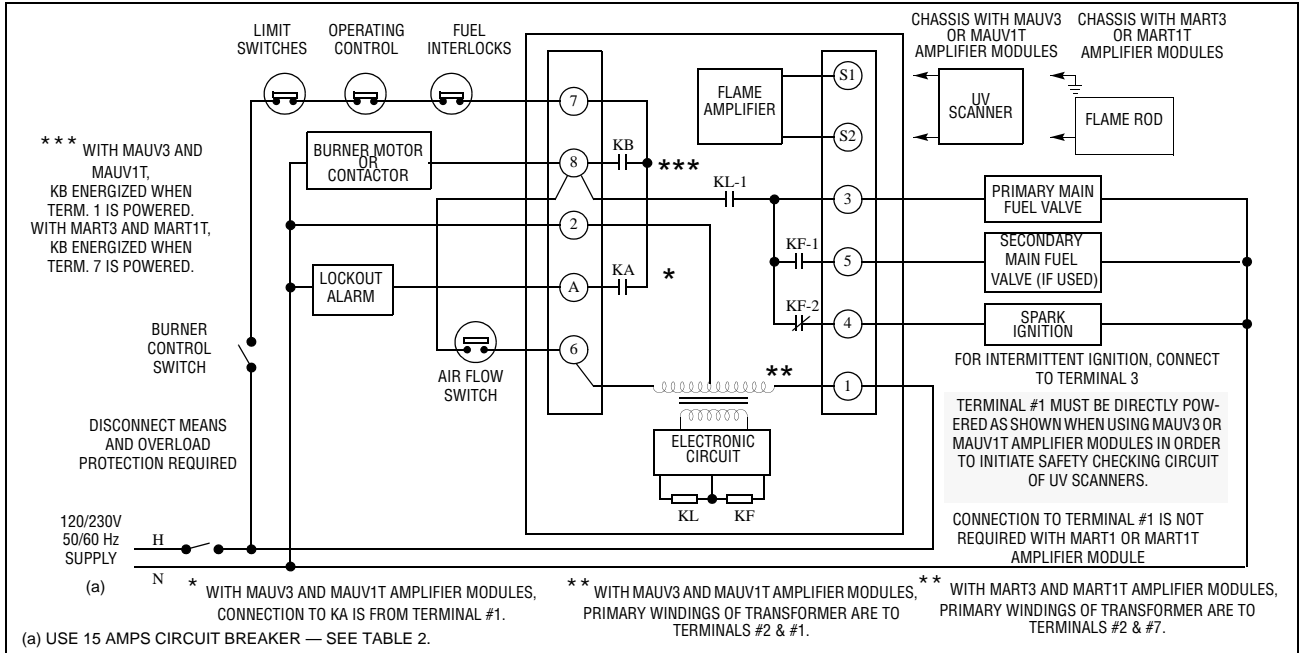

Use moisture resistant wire suitable for at least 90°C.



**CAUTION:** When powered, 560 VAC across S1, S2 with MAUV3 and MAUV1T; 260 VAC across S1, S2 with MART3 and MART1T.



**CAUTION: Control wiring procedures which deviate from those shown in the diagrams may bypass safety functions designed in the control. Check with the Fireye Representative before deviating from the recommended wiring diagrams.**

**FIGURE 3. ALTERNATE WIRING ARRANGMENT FOR MP100 CONTROLS**

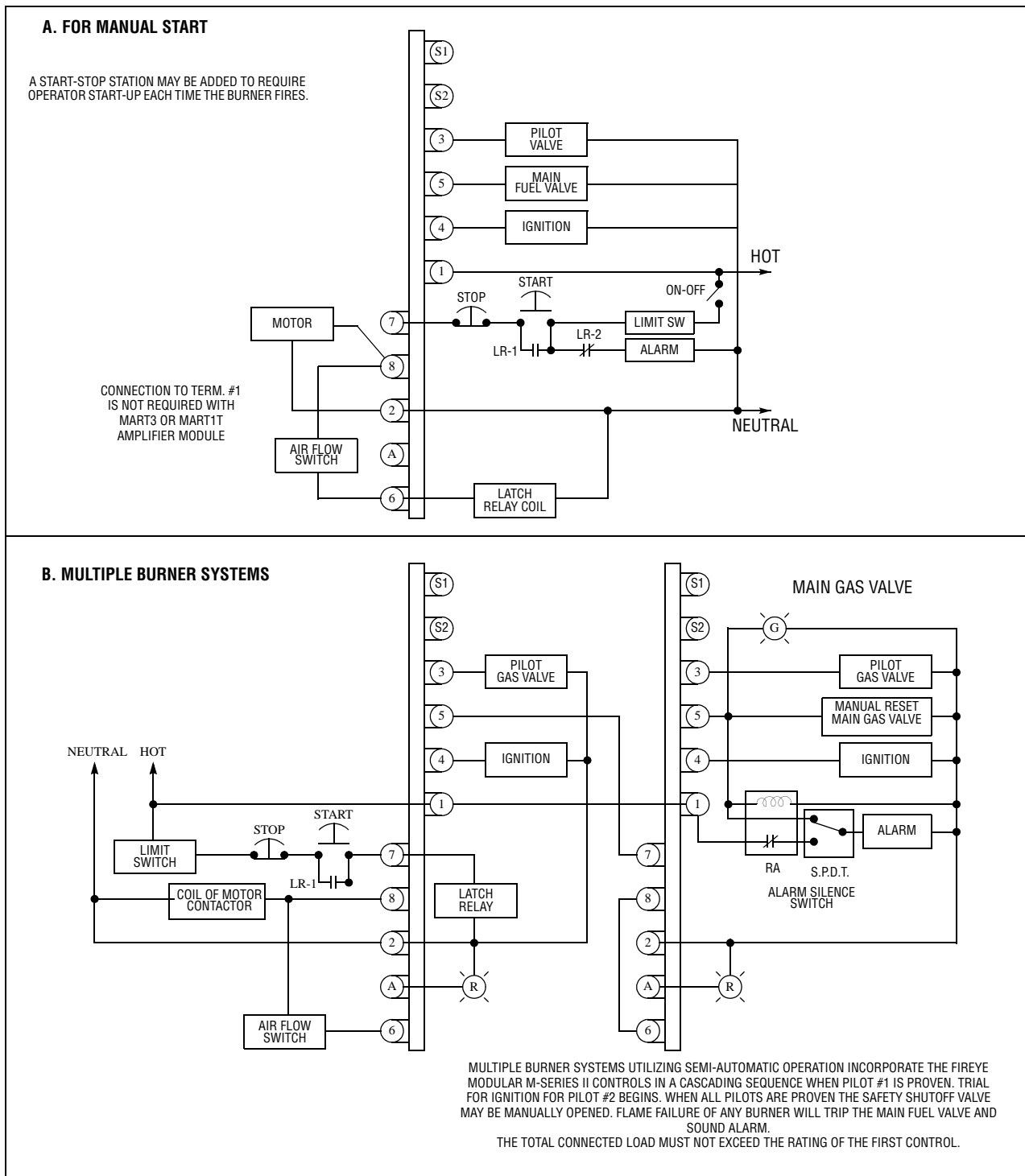

Use moisture resistant wire suitable for at least 90°C.



---

## NOTICE

When Fireeye products are combined with equipment manufactured by others and/or integrated into systems designed or manufactured by others, the Fireeye warranty, as stated in its General Terms and Conditions of Sale, pertains only to the Fireeye products and not to any other equipment or to the combined system or its overall performance.

---

## WARRANTIES

FIREYE guarantees for *one year from the date of installation or 18 months from date of manufacture* of its products to replace, or, at its option, to repair any product or part thereof (except lamps, electronic tubes and photocells) which is found defective in material or workmanship or which otherwise fails to conform to the description of the product on the face of its sales order. **THE FOREGOING IS IN LIEU OF ALL OTHER WARRANTIES AND FIREYE MAKES NO WARRANTY OF MERCHANTABILITY OR ANY OTHER WARRANTY, EXPRESS OR IMPLIED.** Except as specifically stated in these general terms and conditions of sale, remedies with respect to any product or part number manufactured or sold by Fireeye shall be limited exclusively to the right to replacement or repair as above provided. In no event shall Fireeye be liable for consequential or special damages of any nature that may arise in connection with such product or part.



™ FIREYE INC.  
3 Manchester Road  
Derry, New Hampshire 03038

C-4000-E  
JANUARY 3, 2006  
Supersedes April 1995