



DESCRIPTION AND INSTALLATION

**UV self-checking Scanner Models:
55UV5-1007, 55UV5-1009**

**For use only with designated Fireeye® controls
For Infrared Photocell Scanners use SC103
For non self-checking UV Scanners use SC102**

**NEMA 4X, IP66
CLASS I, DIV 2, GROUPS A B C D
CLASS II, DIV 2, GROUPS F G**



IMPORTANT NOTE

The information provided in this bulletin is directed to competent boiler and combustion service technicians who are experienced in the installation and operation of Fireeye Flame Safety equipment. Persons not familiar with Fireeye products should contact the nearest Fireeye representative or other qualified service group.

The 55UV5 scanners as well as all other Fireeye scanners, are designed to be used exclusively with the appropriate Fireeye Flame Safeguard and Burner Management controls. The application of these scanners to other than Fireeye equipment should be reviewed for approval by Fireeye.

APPLICATION

Fireeye 55UV5 self-checking scanners are used to detect ultraviolet emissions from fossil fuel flames such as natural gas, coke oven gas, propane, methane, butane, kerosene, light petroleum distillates and diesel fuels and are suitable for use in Class I, Div. 2, Groups A B C D and Class II, Div. 2 Groups F G hazardous locations. These 55UV5 models are used only with the Flame-Monitor, D-Series, FlameWorx and MicroM control models to provide flame safeguard and monitoring systems for supervised manual, semi-automatic and fully automatic single burner boilers, process ovens and heaters.

PRINCIPLES OF OPERATION

The 55UV5 scanners use a UV-eye detector. This detector is a sealed, gas filled, UV-sensitive tube containing two electrodes connected to a source of AC voltage. When UV radiation of sufficient energy falls upon the electrodes, electrons are released and the inter-electrode gas becomes conductive, resulting in an electric current flow from one electrode to the other. The current flow starts and ends abruptly and is known as an "avalanche."

A very intense source of UV radiation will produce several hundred avalanches or pulses per second. With less radiation there will be fewer pulses per second. Upon total disappearance of flame, the detector output ceases. Thus, the presence or absence of pulses is an indication of the presence or absence of flame; the frequency of the pulses is a measure of flame intensity. Pulses generated by the scanner are transmitted to a compatible Fireeye control via scanner wiring.

FEATURES

The components are contained in a cast aluminum NEMA 4X, IP66 housing sealed with an oil-resistant gasket. The quartz lens is a planoconvex design, resulting in increased sensitivity. Also included in the scanner is an electromagnetic shutter that permits a self-checking circuit to verify that the scanner and signal circuits are producing valid flame presence or absence information. During the shutter closed period, the detector's optical path is blocked from flame radiation, allowing the control system to verify the proper operation of the ultraviolet tube. While the shutter is open, flame presence or absence is detected.

SPECIFICATIONS

FIGURE 1.

DIMENSIONS

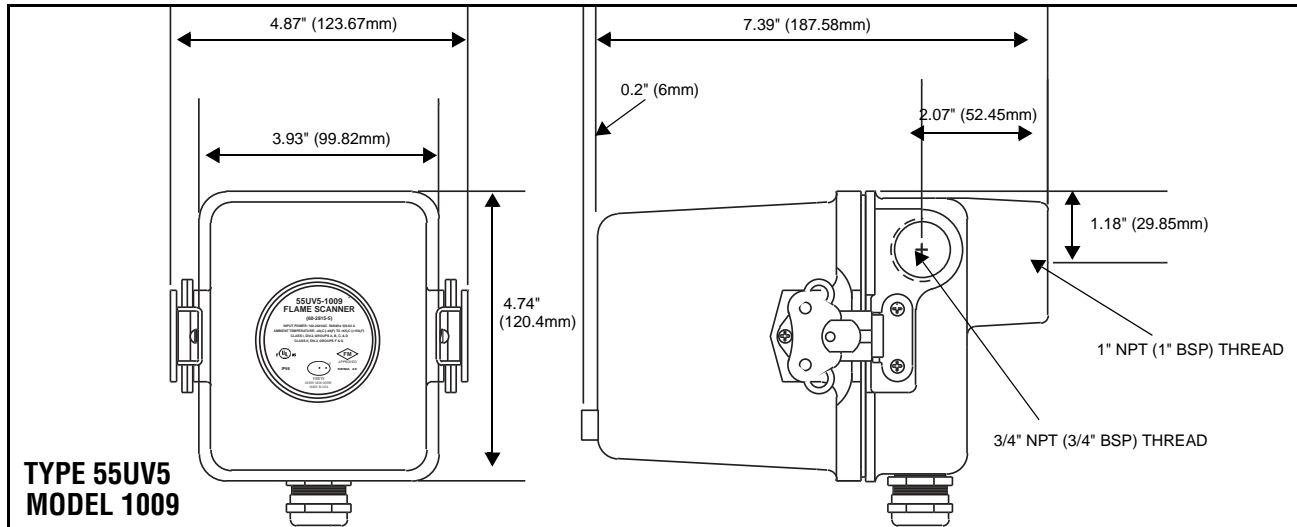

SPECIFICATIONS TABLE

MODEL NO.	THREADS	NOMINAL SHUTTER TOTAL CYCLE PERIOD	VOLTAGE 50/60 HZ		TEMP. RANGE See note 1		USE ONLY WITH CONTROL MODELS	TERMINALS	
			SHUTTER (BLK-WHT)	SIGNAL (BLU-YEL)	MAX.	MIN.		SIGNAL	SHUTTER
55UV5- 1007	1" BSP	0.4 sec. closed 3.6 sec. open	102-264 VAC	560 VAC	140∇F 60∇C	- 40∇F (- 40∇C)	See note 2	S1-S2	L1-L2
55UV5- 1009	1" NPT	0.4 sec. closed 3.6 sec. open	102-264VAC	560VAC	140∇F 60∇C	- 40∇F (- 40∇C)	See note 2	S1-S2	L1-L2

NOTE 1: In non-hazardous locations the maximum operating temperature is 199°F (93°C).

NOTE 2: Flame-Monitor, EUVS4; D-Series, 72DUVS1T, 72DUVS4; MicroM, MEUVS1, MEUVS4; FlameWorx; MBUVS-301D, MBUVS-311D.

SPECIFICATIONS

MECHANICAL:

Housing Material:	Cast aluminum with grey epoxy coat finish
Housing Weight:	4 lbs (2kg)
Environmental:	NEMA 4X, IP66
Hazardous Classifications:	Class I, Div. 2, Groups A B C D Class II, Div. 2, Groups F G Temperature rating T6 at 140°F (60°C) ambient



CAUTION: Spring fasteners should be clipped and tightened to ensure a good bond to housing and maintain the integrity of the NEMA 4X rating.

Mounting: Model 1009: 1" NPT female pipe mount with 3/4" NPT female cooling air connection
 Model 1007: 1" BSP female pipe mount with 3/4" BSP female cooling air connection

Cooling / Purge Air Requirements:

Source: Clean, dry, cool
Volume: 4 SCFM (113 l/min) at 3/4" threaded mounting flange, or 1 inch "Y" fitting, mounted on scanner sight pipe. Temperature near the upper limit of the scanner operating range and/or use with dirty/dusty fuels may require up to 15 SCFM (425 l/min).
Pressure: Adequate to overcome furnace or windbox pressure

Temperature Rating:

CONDITION	MIN.	MAX.
Non-hazardous	-40°F (-40°C)	+199°F (93°C)
Class I, Div 2, Groups A B C D Class II, Div 2, Groups F G Using Anaconda 1/2" Type H.V.T.A. liquid tight	-40°F (-40°C)	+140°F (60°C) T6 Rating
Class I, Div 2, Groups A B C D Class II, Div 2, Groups F G Using customer supplied conduit or liquid tight connection	-40°F (-40°C)	+199°F (93°C) T4A Rating

Humidity: 0% to 95% relative humidity, non-condensing
Optical Range: 220 to 260 nm. No response to infrared radiation or visible light
Optical Field of View: 1 inch per foot (25.4mm/305mm)
Operating Range: 72 inches (1830mm) or less

ELECTRICAL:

Electrical Connection: Cable gland and 20 ft (6m) of five conductor cable

INTEGRAL CABLE SPECIFICATION:

Individual Conductors

Three (3) Conductors: #18 AWG (16x30) strand tinned copper
Diameter: 0.110" Nominal O.D.
Colors: Green, White and Black
Two (2) Conductors: #22 AWG (7x30) strand tinned copper
Diameter: 0.093" Nominal O.D.
Colors: Blue and Yellow
Insulation Material: EXAR 150A .074" nominal O.D.
Cable:
Jacket Material: EXAR 150A .074" pressure extruded
Wall Thickness: .045" NOM.
Finished Diameter: .418" NOM.
Temperature: -40°F (-40°C) to 257°F (125°C)

AGENCY CERTIFICATIONS

Underwriters Laboratory: MCCZ2, File MP1537
 Controls, Primary Safety - Component
 MCCZ8, File MP1537
 Controls, Primary Safety Certified for Canada

Factory Mutual: Approved, FM class 7610 and 3611

ORDERING INFORMATION

PART NUMBER	DESCRIPTION
55UV5-1007	UV self-check scanner, NEMA 4X, IP66, meets Class I, Div. 2, Groups A B C D and Class II, Div. 2 Groups F G. Scanner head is 1" BSP with 3/4" BSP purge hole, 20 foot cable and liquid tight connector.
55UV5-1009	UV self-check scanner, NEMA 4X, IP66, meets Class I, Div. 2, Groups A B C D and Class II, Div. 2 Groups F G. Scanner head is 1" NPT with 3/4" NPT purge hole, 20 foot cable and liquid tight connector.
61-7074-3	Replacement, front mount, 1" NPT, 3/4" NPT purge hole, 20 foot cable, liquid tight fitting.
61-7074-4	Replacement, front mount, 1" BSP, 3/4" BSP purge hole, 20 foot cable, liquid tight fitting.
60-2518-5	Replacement, UV self-check scanner electronics assembly, 55UV5-1009 Series
60-2518-6	Replacement, UV self-check scanner electronics assembly, 55UV5-1007 Series
4-314-1	UV tube
61-7075-1	Shutter replacement assembly

SCANNER MOUNTING

The 55UV5 scanner is provided with a male connector located in the scanner electronics and two alignment pins and a female connector located in the front mount.

For ease of installation, it is recommended that the scanner front mount be installed to the burner sight pipe separately.

To remove the scanner electronics from the front mount first remove the two locking bracket clips from the quarter turn latches. Turn the quarter turn latches to disengage the scanner electronics from the front mount. Pull the scanner electronics away from the front mount. To re-install, reverse the procedure.

To maintain compliance, it is necessary to re-install the locking bracket clips.

FIGURE 2.

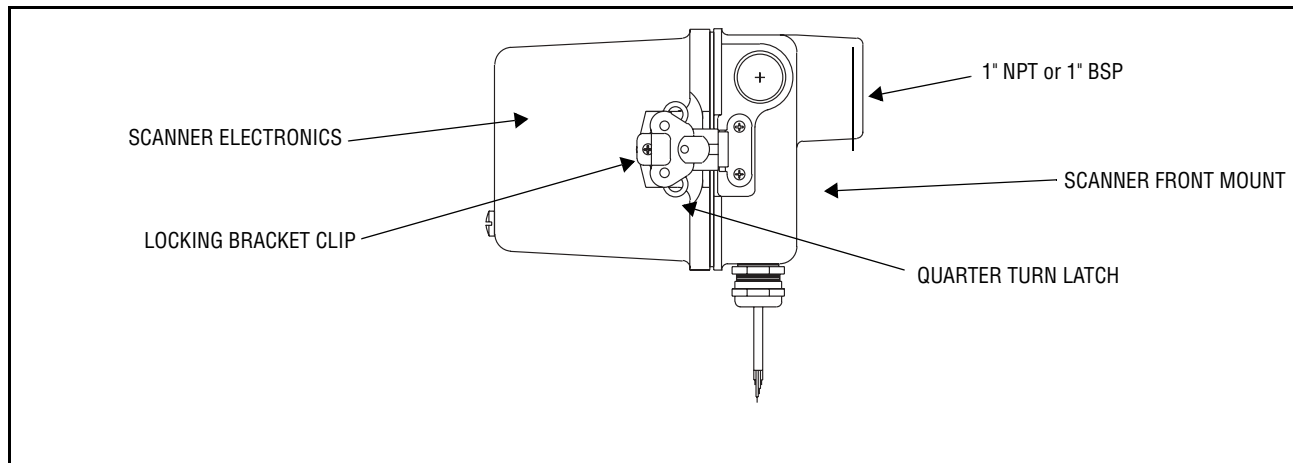

SCANNER WIRING

All FIREYE controls are protected against short-circuited scanner input terminals. The following recommendations apply for scanner control wiring:

- Do not run scanner cables in the same conduit as other electrical wires.
- Avoid wire loops and poor groundings.
- Keep high voltage ignition wires well away from scanner wires.



CAUTION: REMOVE ALL POWER BEFORE SERVICING

Scanner Connections:

CONTROL	BLACK	WHITE	BLUE	YELLOW	GREEN
Flame-Monitor	L1	L2	S1	S2	Connect to Earth Ground
D-Series	L1	L2	S1	S2	
MicroM	1	2	S2	S1	
FlameWorx -ch1 -ch2	LINE HOT	LINE NEUTRAL	21 20	23 22	

1. Selection of wire
 - Use #14, 16, or 18 wire with 75 C, 600 volt insulation for up to 100 foot distances (signal loss approximately 20% at 100 feet).
 - Asbestos insulated wire should be avoided.
 - Multiconductor cable is not recommended without prior factory approval.
 - **Extended Scanner Wiring.** For extended scanner wiring up to 1500 feet, and for shorter lengths to reduce signal loss, use a shielded wire (Belden 8254-RG62U) coaxial cable, or equal **for each blue and yellow wire** of the 55UV5. The ends of the shielding must be taped individually on both ends and not grounded.

For multiple burner installations:

2. Distances are decreased when more than one set of scanner leads are installed in a common conduit. For example, the maximum distance for 2 scanners is 750 feet and for 3 or more scanners the distance decreases to 500 feet.
3. High voltage ignition wiring should not be installed in the same conduit with flame detector wires.

Note: When used for a Class I, Div 2 application, the liquid tight flexible conduit (Anaconda Sealtight® 1/2" Type H.T.V.A or equivalent, available at any electrical supply outlet) can be inserted over the existing cable. The maximum ambient temperature allowed is 140°F (60°C).

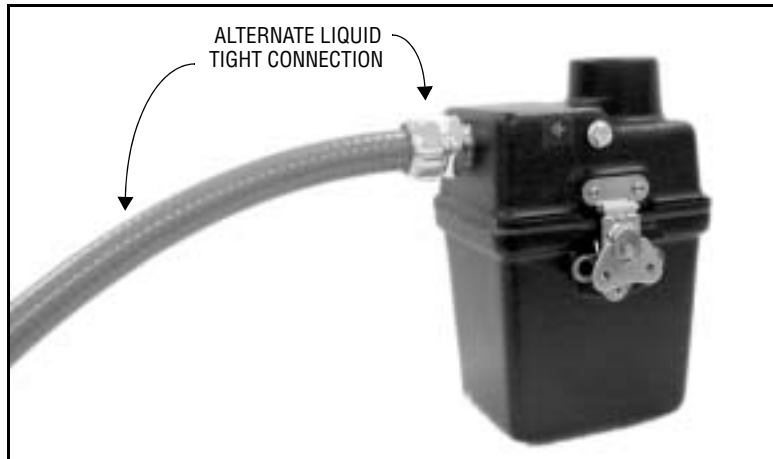

For applications in hazardous locations that require operation greater than 140°F (60°C) and up to the maximum operating temperature of the scanner (199°F (93°C)), it is the user’s responsibility to supply an alternate conduit or liquid tight connection that can meet those required temperature ratings.

INSTALLATION

The best scanner sighting results are obtained when the scanner is aimed so that its line of sight intersects the burner center line at a slight angle, as shown in Figure 3. The area of maximum ultraviolet radiation is near the base of the flame envelope. When only one scanner is used per burner, the intersection should be made so the line of sight or viewing angle can also see the pilot flame. Consideration must be given to burner secondary air rotation (some burners have clockwise air rotation and others counter-clockwise). Figure 4 illustrates how scanner location is influenced by the pilot positions and secondary air circulation. Physical obstructions such as air register blades should not fall in the line of sight of the scanner.

FIGURE 3.

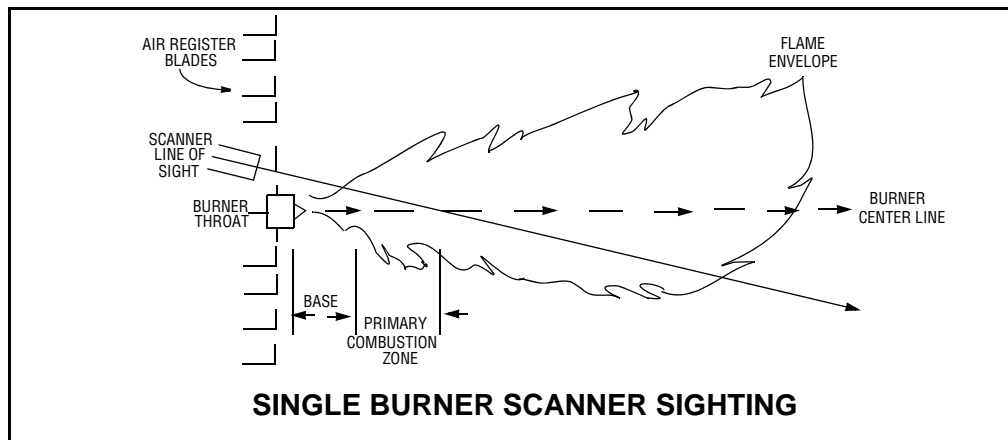

4. AN ACCEPTABLE SCANNER LOCATION MUST ENSURE THE FOLLOWING:
 - Reliable pilot flame detection.
 - Reliable main flame detection.
 - Rejection of pilot flame too short or in the wrong position to ignite the main flame reliably, thus prohibiting main fuel admission.

Note: Reliable signals must be obtained at all air flows and furnace loads (ranges of fuel firing).

FIGURE 4.

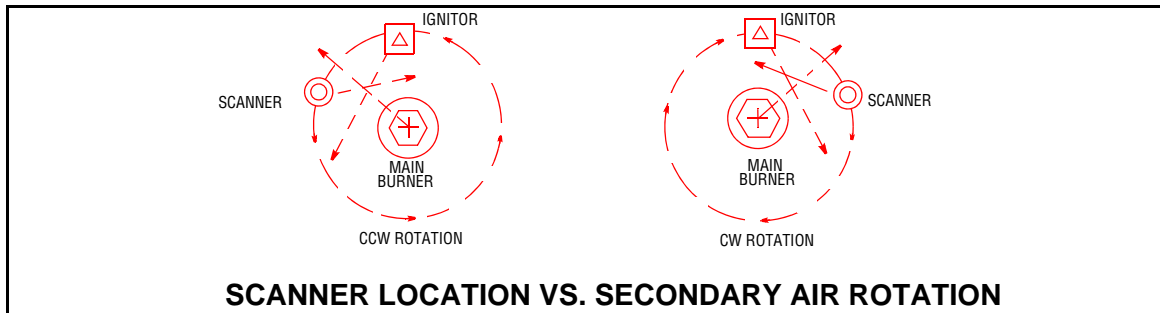

5. If combustion air enters the furnace with a rotational movement of sufficient velocity to deflect pilot flame in direction of rotation, position the scanner 0 to 30 degrees downstream of the pilot burner and close to the periphery of the throat where the ultraviolet radiation is at a maximum. (See Figures 3 and 4).
6. Having determined an appropriate location for the sight tube, cut a clearance hole for a 2 inch pipe through the burner plate. If register vanes interfere with the desired line of sight, the interfering vane(s) should be trimmed to assure an unobstructed viewing path at all firing levels, see Figure 5.
7. Mount scanner sight pipe by either:
 - Centering a Fireye No. 60-1664-3 (NPT) or 60-1664-4 (BSP) swivel mount over the hole and installing the sight pipe on the swivel mount,

or

 - Inserting the end of the sight pipe into the hole, aligning the pipe to the desired viewing angle and tack welding. (Welding must be adequate to temporarily support the weight of the installed scanner). The sight pipe should be arranged to slant downward so that the dirt and dust will not collect in it.

FIGURE 5.



8. When a satisfactory sighting position has been confirmed by operational test, (see section on alignment), the sight pipe should either be firmly welded in place or, if the swivel mount is used, the base position should be secured by tightening the three hex head cap screw located on the swivel mount ring. In certain older style swivel mounts, tack welding may be required.
9. Excessive flame signal can affect flame discrimination and prevent the control connected to the scanner from performing properly. To reduce the signal level of the tube, or improve flame discrimination, orifices may be installed to decrease the scanner's field of view and reduce its sensitivity. Installation of the orifice disk is shown in Figure 8.
10. The scanner viewing window must be kept free of contaminants (oil, smoke, soot, dirt) and the scanner temperature must not exceed its maximum rating. Both requirements will be satisfied by continuous injection of purge air.

The scanner mounting may be made with provision for purge air through the 3/4" opening as shown in Figure 6, Item A or C, or through a 1" tee/wye connection as shown in Figure 6, Item B. Normally only one of the two connections is provided with purge air and the other is plugged. When a Fireye union is used as shown in Figure 6, the 1" tee/wye connection is used for the purge air (plug 3/4" opening).

Under normal temperature conditions, with clean burning fuels and moderate ambient temperature conditions, purge air flow of approximately 4 SCFM (113 L/min) is generally adequate. A 0.1 psig

positive pressure difference between the atmosphere and boiler pressure measured at right angle to the purge air flow, should result in a purge air flow of 4 SCFM. Up to 15 SCFM (425 L/min) may be required for fuels that may produce high levels of smoke of soot or for hot environments to maintain scanner internal temperature within specifications.

Note: The maximum viewing field of the lens is one inch per foot. Do not use more than one foot of one inch sight pipe. Increase sight pipe diameter one inch for every additional foot of sight pipe length used, to avoid restricting the scanner's field of view. Temperature in the scanner housing should not exceed those temperature limits listed in the specifications. Excessive temperatures will shorten scanner life.

FIGURE 6.

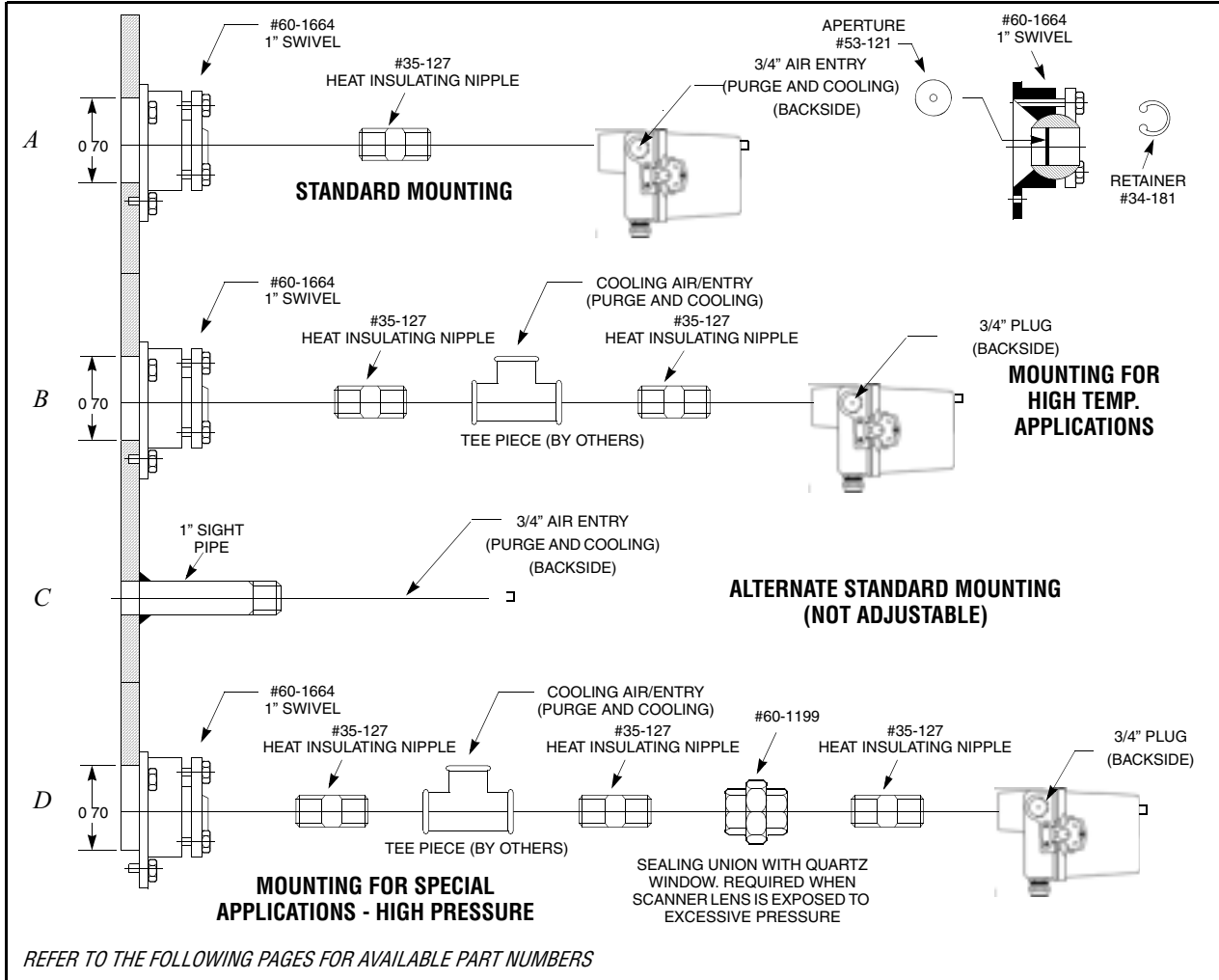

ALIGNMENT AND ADJUSTMENTS

The following procedures are recommended to ensure optimum flame detection and discrimination. Flame discrimination is the ability to see only one burner or one pilot with other burners or pilots operating nearby. These procedures should be used whenever parts are replaced, when the scanner has been moved, when the flame shape is altered (additional fuels, new burners, burner/register modifications) as well as on all new installations.

Pilot Flame Scanner

1. Apply power to scanner and associated control.

2. Start pilot.
3. Adjust scanner sighting to detect pilot flame in the manner shown in Figure 5.
4. When flame is properly sighted, the flame signal should correspond to the acceptable ranges indicated in the appropriate bulletin for each compatible FIREYE control. If readings fluctuate widely, readjust scanner sighting until highest, steadiest reading is obtained.
5. When the proper signal reading has been obtained, make sure that the scanner and the associated control do not respond to the ignition spark. This is accomplished by cutting off the fuel to the pilot and attempting to start the pilot using the spark igniter. If the system responds to the spark, the sighting should be realigned.

Main Flame Scanner

1. Apply power to scanner and associated control.
2. Start pilot.
3. Adjust scanner sighting so that ignition spark and pilot flame are not detected. Test should be conducted with maximum pilot flame and with both minimum and maximum airflow.
4. Start main burner.
5. Adjust scanner sighting to detect main burner flame. When sighting is correct (see above), the signal should be read in the acceptable range for the control in use, without extreme fluctuations.
6. When proper signal is established, manually close off the main burner fuel supply. When burner flame becomes unstable or is extinguished, the control should register a “flame failure” condition.
7. Start an adjacent burner and vary its firing rate under normal airflow conditions. Make certain that the main flame scanner on the burner not in service does not respond to adjacent burner flame. Readjust sighting if necessary.



CAUTION: Minimum pilot is the minimum flame required to satisfactorily ignite the main burner. Be sure to test for reliable signals under maximum airflow conditions when the pilot may be detected outside the line of sight. If this occurs, resighting is required.

SWIVEL MOUNT

The scanner swivel mount P/N 60-1664-4 (BSP) 60-1664-3 (NPT) is used to adjust the scanner sighting angle after the scanner has been installed. The swivel mount is used as indicated the figures in this document.

Orifices

The Orifice restricts the field of view (target area), reduces air flow, maintains air flow, maintain air block, and increases discrimination between flame and background radiation. The orifice is secured within the ball of a swivel mount with an orifice retainer or the orifice can be placed within a one inch union (not provided).

The scanner should ideally sight a target area of 4 to 25 square inches (25-150 cm²) of the flame front. The flame front is a plane within the combustion space separating the region of unburned fuel from the burning fuel.

Note: There is an inverse relationship between discrimination and sensitivity.

Heat Insulating Nipple

The heat insulating nipple P/N 35-127-3 (BSP); 35-127-1 (NPT) prevents heat transfer from the hot sight pipe to the scanner head.

Sealing Union with Quartz Window

The sealing union (60-1199) is used whenever a union or seal is required for scanner piping. The size is one inch US standard taper pipe thread (1" NPT). The sealing union has a quartz window to block off the scanner from the furnace pressure and heat. When the sealing union is used, the 1" tee/wye is used for the purge air inlet. Be sure the quartz window is properly seated to seal off the scanner. Do not over-tighten union collar because damage to the window may result. For best results, hand tighten union collar.

UV TUBE REPLACEMENT PROCEDURE

In the event the internal UV tube (4-314-1) needs replacement the following procedure is recommended:



CAUTION: REMOVE ALL POWER BEFORE SERVICING

FIGURE 7.

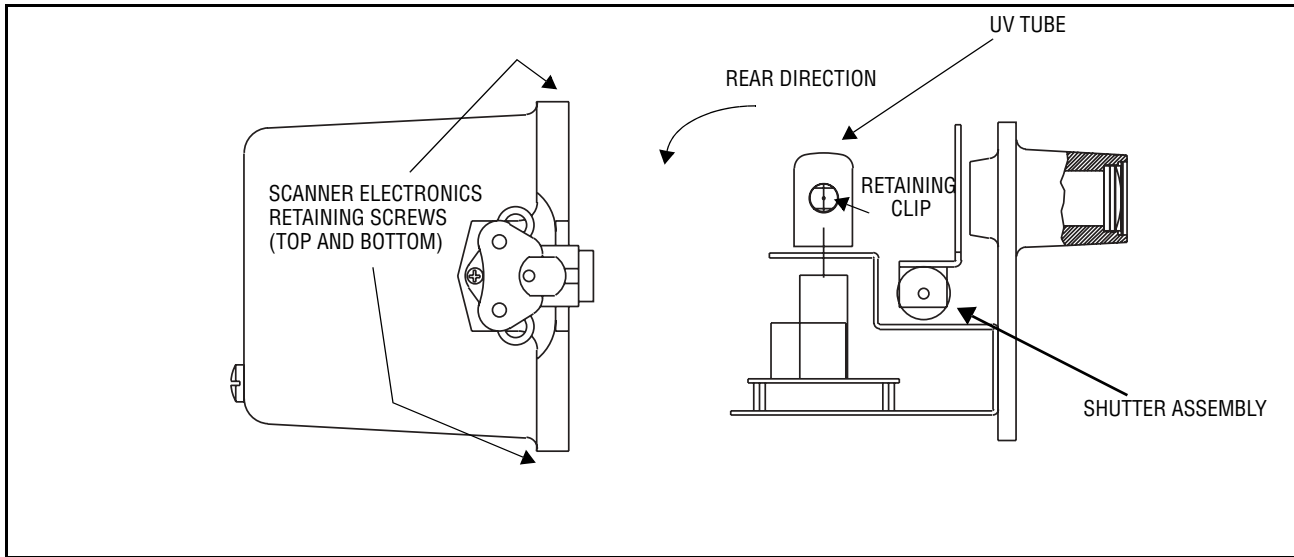

1. Remove scanner from front mount.
2. Loosen screws on top and bottom.
3. Pull scanner electronics from housing.
4. Push UV tube retainer toward rear.
5. Lift UV tube from socket.
6. Insert new UV tube into socket, electrodes parallel with front plate.
7. Wipe away any residue from tube surface.
8. Pull UV tube retainer up and over UV tube.
9. Insert scanner electronics back into housing.
10. Tighten screws on top and bottom.
11. Re-install scanner to front mount.

FIGURE 8.

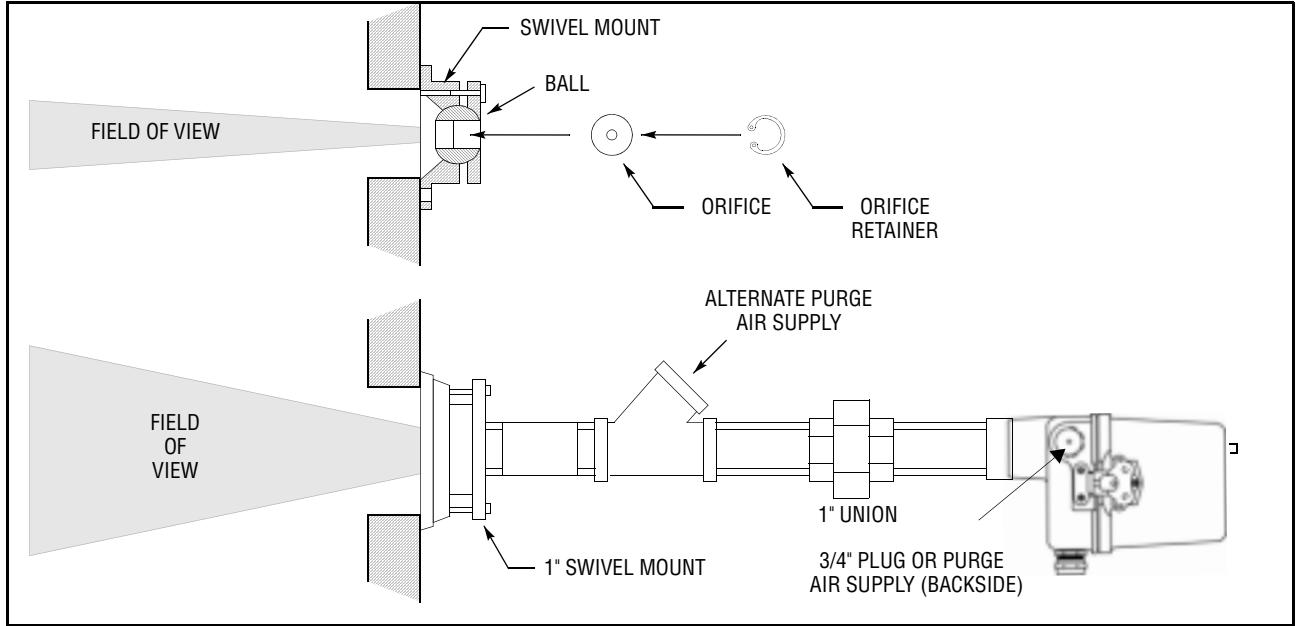

PART NUMBERS AND ACCESSORIES

FIGURE 9.

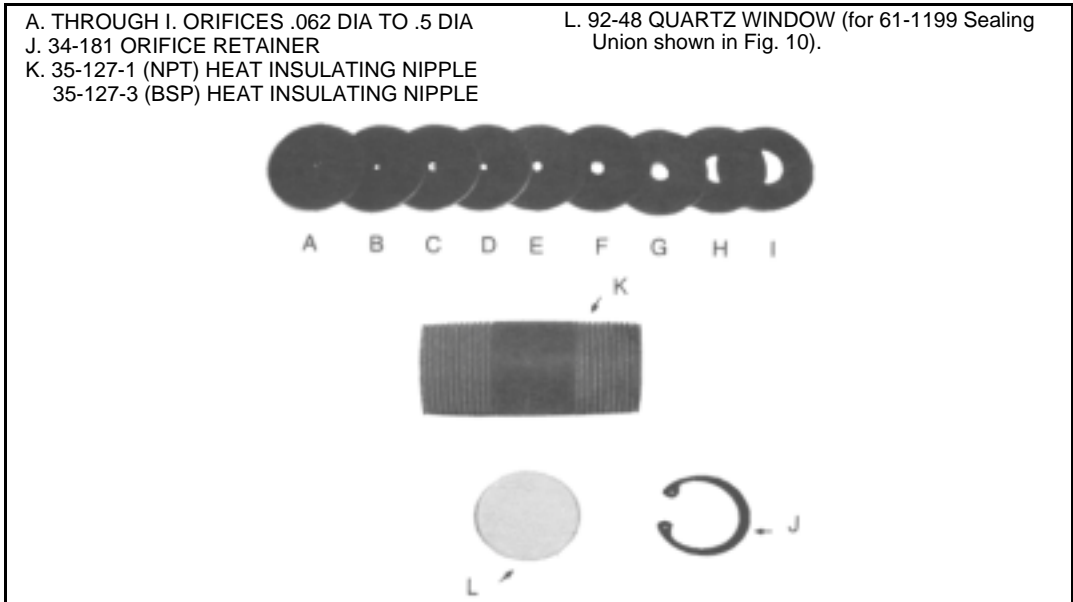
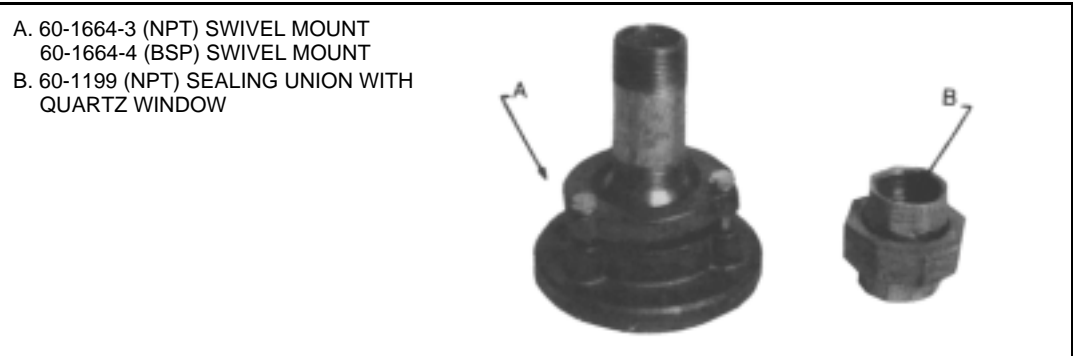

FIGURE 10.





ACCESSORIES

FIGURE	PART NUMBER	DESCRIPTION
9A	52-121-2	Orifice .062" Diameter
9B	53-121-3	Orifice .078" Diameter
9C	53-121-4	Orifice .093" Diameter
9D	53-121-5	Orifice .109" Diameter
9E	53-121-6	Orifice .125" Diameter
9F	53-121-7	Orifice .187" Diameter
9G	53-121-8	Orifice .250" Diameter
9H	53-121-9	Orifice .375" Diameter
9I	53-121-10	Orifice .50" Diameter
	35-200	1" NPT Wye
	35-201	1" NPT Close Nipple
	10-216	PLUG 3/4" NPT

NOTICE

When Fireye products are combined with equipment manufactured by others and/or integrated into systems designed or manufactured by others, the Fireye warranty, as stated in its General Terms and Conditions of Sale, pertains only to the Fireye products and not to any other equipment or to the combined system or its overall performance.

WARRANTIES

FIREYE guarantees for *one year from the date of installation or 18 months from date of manufacture* of its products to replace, or, at its option, to repair any product or part thereof (except lamps and photocells) which is found defective in material or workmanship or which otherwise fails to conform to the description of the product on the face of its sales order. **THE FOREGOING IS IN LIEU OF ALL OTHER WARRANTIES AND FIREYE MAKES NO WARRANTY OF MERCHANTABILITY OR ANY OTHER WARRANTY, EXPRESS OR IMPLIED.** Except as specifically stated in these general terms and conditions of sale, remedies with respect to any product or part number manufactured or sold by Fireye shall be limited exclusively to the right to replacement or repair as above provided. In no event shall Fireye be liable for consequential or special damages of any nature that may arise in connection with such product or part.



FIREYE
3 Manchester Road
Derry, New Hampshire 03038 USA
www.fireye.com

SC-106
JUNE 23, 2006
Supersedes May 10, 2006