



INSTALLATION INSTRUCTIONS

133-674

Flame-Monitor EP178/EP378 Programmers with EDC1/EDC2 Amplifiers using Phoenix and InSight Scanners

INSTALLATION INSTRUCTIONS

The Fireeye Flame-Monitor programmers, type EP178 and EP378, with the EDC1 or EDC2 amplifiers, are specially designed to operate as a primary burner control use specific models of the InSight and Phoenix integrated scanners as the flame detector. Specific models of the InSight scanners are 95IRS1-1, 95IRS2-2, 95UVS1-1, 95UVS2-2, 95DSS1-1, 95DSS2-2. **Use of cable assembly 59-497-020-WR, 59-497-020C-WR, 59-497-020R-WR, or 59-497-020RC-WR is necessary to make the InSight scanner compatible with the Flame-Monitor system.** Specific models of the Phoenix scanners are 85UVF4-1WR, 85IRF4-1WR, 85UVF4-1EX-WR and 85IRF4-1EX-WR. **Refer to bulletins E-1101, EAMP1, CU-95 and CU-105 for detailed installation and operational information.**

The Fireeye E110 FLAME-MONITOR™ System is a microprocessor based burner management control system designed to provide the proper burner sequencing, ignition and flame monitoring protection on automatically ignited oil, gas, and combination fuel burners. In conjunction with limit and operating controls, it programs the burner/blower motor, ignition and fuel valves to provide for proper and safe burner operation. The control also provides current operating status and lockout information in the event of a safety shutdown.

Along with new unique amplifiers, the Flame-Monitor firmware was modified to allow the integration of the InSight and Phoenix scanners into the Flame-Monitor family of primary safeguard controls to provide continuous self-checking operation. Flame-Monitor algorithms precisely and continuously check the signal from the Phoenix scanners, such that a short circuit across the amplifier input would result in a safety shutdown and lockout.

The Fireeye Phoenix scanner types 85UVF4-1WR, 85IRF4-1WR, 85UVF4-1EX-WR and 85IRF4-1EX-WR are unique versions of the standard Phoenix microprocessor based devices specifically designed to interconnect and operate with Fireeye Flame Safeguard Controls. The -1EX versions are rated for installation in hazardous locations and are rated Class 1, Div 2, Group A, B, C, and D.

The Phoenix flame scanners incorporate an internal flame relay with automatically set ON/OFF thresholds. Phoenix scanners detect the amplitude of the modulations (the flame "flicker") that occur within the targeted flame, over a wide frequency. During the scanner set-up procedure, the amplitudes of the target flame are automatically stored by the flame scanner, along with the optimum ON/OFF criteria. The appropriate sensor gain is automatically selected.

The FIREYE InSight Type 95IR, 95UV, and 95DS flame scanners are micro-processor based flame scanners utilizing solid state infrared (IR) or ultraviolet (UV) or dual (IR and UV) sensors. The FIREYE InSight Type 95 flame scanners incorporate an internal flame relay with adjustable ON/OFF thresholds. The InSight scanners incorporate elements of the FIREYE Type 45FS1 and 45UVFS1 Signature Scanners™ as well as of the Type 45RM4 flame scanners to detect the presence or absence of a target flame in single or multi-burner applications.

The InSight scanners measure the amplitude of the modulations (the flame "flicker") that occur within the targeted flame. During the scanner set-up procedure, the modulation frequency that yields the best flame ON/OFF discrimination is selected. The appropriate modulation frequency and sensor gain is either manually selected (S1 models), or automatically selected with manual override capability (S2 models).



In order to meet compliance with national and local codes, the InSight scanner must have its FFRT (flame failure response time) set to no more than 3 seconds.

The Standard Model S1 has three choices of modulation frequency, adjustable sensor gain, adjustable flame relay ON/OFF thresholds, 4-20 mA analog signal strength output, fault relay, and two selectable programmable files to store setpoints (for two different fuels or firing rates).

The Expanded Model S2 adds automatic programming (AutoTune) with manual override capability, 21 choices of flame flicker frequency, a total of four selectable programmable files to store setpoints, plus adds remote communication capability via Fireye Windows 95/98/NT user software. All FIREYE InSight scanner models are powered by 24 Vdc and contain electronic self-checking (no mechanical shutter required). The scanners contain an eight character alpha-numeric LED display and a four (4) push-button keypad to enable the user to view operating parameters and select setpoints.

For extremely hot or dirty applications, the Phoenix scanner mounting flange P/N 35-318-1 has provisions for purge air (see bulletin CU-105, Fig. 1). In typical line burner applications, simply leaving the fitting open will allow sufficient air to pass through to keep moisture out.

All models of the Phoenix flame scanners are housed within an engineered material making them incredibly strong but lightweight and easy to handle. The housing material is designed to meet the requirements of NEMA 4X (IP66). The InSight scanner housing is cast aluminum with gray polyester powder coat finish and meets NEMA 4X, IP66, Class 1 Division II, Groups A, B, C, & D, Class 2 Division II, Groups F & G.

The Phoenix and InSight flame scanners are powered by 24Vdc (supplied separately). The 24 Vdc supply must be powered from the same mains supply as the E110 Flame-Monitor. See wiring diagrams.

SCANNER ORDERING INFORMATION

PHOENIX	
85UVF4-1WR	Phoenix Integrated Scanner, 4 sec FFRT – Ultra-violet with 10 foot cable. FM, UL_cus approved.
85UVF4-1EX-WR	Phoenix Integrated Scanner, 4 sec FFRT – Ultra-violet with 10 foot cable. Suitable for Class 1, Div 2. Group A, B, C, and D. FM, UL_cus approved.
85IRF4-1WR	Phoenix Integrated Scanner, 4 sec FFRT – Infrared with 10 foot cable. FM, UL_cus approved.
85IRF4-1EX-WR	Phoenix Integrated Scanner, 4 sec FFRT – Infrared with 10 foot cable. Suitable for Class 1, Div 2. Group A, B, C, and D. FM, UL_cus approved.
35-318-1	Mounting flange for Phoenix, 1" NPT
35-318-2	Mounting flange for Phoenix, 1" BSP
INSIGHT	
95IRS1-1	Standard Model InSight Scanner – infrared with quick disconnect, FM, CSA approved.
95UVS1-1	Standard Model InSight Scanner – Ultra-violet with quick disconnect, FM, CSA approved.
95DSS2-1	Standard Model InSight Scanner – Dual detector with quick disconnect, FM, CSA approved.
95IRS2-1	Enhanced Model InSight Scanner – infrared with quick disconnect, FM, CSA approved.
95UVS2-1	Enhanced Model InSight Scanner – Ultra-violet with quick disconnect, FM, CSA approved.
95DSS2-1	Enhanced Model InSight Scanner – Dual detector with quick disconnect, FM, CSA approved.
60-2692	1" NPT mounting flange for InSight Scanner, includes heat insulator 35-127-1.
60-2693	1" NPT mounting flange for InSight Scanner, includes heat insulator 35-127-3.
CABLES	
59-497-020-WR	Cable, using 59-497 with straight connector (129-164). 20 feet.
59-497-020C-WR	Cable, using 59-497 with straight connector (129-164C) and flex conduit adapter. 20 feet.
59-497-020R-WR	Cable, using 59-497 with right angle connector (129-164R), 20 feet
59-497-020RC-WR	Cable, using 59-497 with right angle connector (129-164RC) and flex conduit adapter. 20 feet
POWER SUPPLIES	
60-2685-2	Power Supply, 24 VDC, 2.1A, 120.240 VAC
60-2685-4	Power Supply, 24 VDC, 4.2A, 120.240 VAC



DESCRIPTION

EP378 Programmer Operation

The EP378 programmer is specifically designed to be used with an external valve proving system. The contacts of this module are located between terminals 13 and 3. The start of a cycle, as determined by a contact closure between terminals L1-13, signals the valve proving sequence to begin and when completed will close its contacts that are located between terminals 13 and 3 of the Flame-Monitor. These contacts must be closed within 1 minute after the completion of low fire start.

EDC1 amplifier

The EDC1 amplifier provides connection for 1 or 2 Phoenix or InSight scanners connected in parallel to terminals S1 and S2. With this amplifier, loss of flame in the connected scanner, or in the case of two scanners connected in parallel, loss of flame in both scanners will cause a burner shutdown and subsequent lockout. Conversely, detection of flame in any connected scanner will indicate a presence of flame. In this mode, the white/red and black/red wires from the Phoenix and InSight are connected to terminals S1 and S2.

NOTE: For maximum immunity against electrical interference, the shield wire of the Phoenix and InSight cable **MUST** be connected to earth ground.

EDC2 amplifier

The EDC2 amplifier provides connections for 2 Phoenix or InSight scanners arranged such that 1 scanner is used to detect pilot flame and the second scanner is used to detect main flame. The purpose of the EDC2 amplifier is to detect pilot with the first scanner and then prove main flame propagation in a line burner using the second scanner. During the main flame period or AUTO, the pilot scanner is completely ignored. Conversely, during pilot and main establishing periods, the main scanner is completely ignored.

SCANNER CONNECTION TABLE USING EDC2			
Phoenix or InSight	White/Red	White/Black	ED510 Display Output
Pilot Detection	S1	L2	28-34
Main Flame	S2	L2	35-43

NOTE: For maximum immunity against electrical interference, the shield wire of the Phoenix and InSight cable **MUST** be connected to earth ground.

MODIFYING THE PROGRAMMER

1. Insert the EP programmer module into the EB700 chassis and connect the ED510 Keypad/Display.
2. Open the operating control (L1-13) circuit. The EP programmer cannot be modified unless the operating control is open and the unit is in STANDBY.
3. The PROGRAM SETUP sub-menu will be used to display the programmable functions. Press the SCRL key until the PROGRAM SETUP sub-menu is displayed.
4. Press the MODE key to enter the PROGRAM SETUP sub-menu. The SCRL key will advance through the selections in the sub-menu. The first four items displayed in the sub-menu are: PROGRAMMER TYPE EP178, ENGR CODE, AMPLIFIER TYPE AND FFRT TIME 4 S. These items are not programmable.
5. Press the SCRL key and the next item displayed (and first programmable item) is PURGE TIME followed by the current setting (default setting = 30 seconds). The available purge timings are from 30 seconds to 37 minutes.



6. Press and hold the RESET button for 1 second to enter the “Modify” mode (providing the control was not in a lockout condition). After a 2-3 second delay, the control will display SCRL TO MODIFY on the top line of the display (replacing STANDBY).
7. Press the SCRL key to advance through the allowable selections. The selections will roll over from the last selection to the first one.
8. Press and hold the RESET button for one second to choose and store in memory the appropriate selection.

Programming the Flame-Monitor EP178 programmer module:

The EP178 Programmer Module provides proven high fire purge and low fire start, early spark termination for the spark ignition that is connected to terminal 5, and waits indefinitely for the M-D low fire start switch to close before the start of pilot trial of ignition. This programmer model also provides a number of operational characteristics that are selected via the ED510 Keypad/Display rather than by dip switch selection.

When in a modifiable selection, the RESET key is used to enter the modify mode, the SCRL key is used to modify the value and the RESET key is used to save the value.

The following is a list of the programmable functions associated with the EP178 Programmer Module:

- Selectable purge (selectable from 30 seconds to 37 minutes – default setting is 30 seconds).
- Prove the operation of the 3-P Running Interlock Circuit at start- default is NO.
- Terminal 6 operation - Interrupted / Intermittent operation of pilot valve – default is interrupted.
- Prove the operation of the High Fire Purge Interlock (D-8) - default is NO.
- Prove the operation of the Low Fire Start Interlock (M-D) - default is NO.
- Purge Count method, UP or DOWN – default is down.
- Selectable Post Purge Timing of 1, 15, 30, or 60 seconds – default is 15 seconds.

Programming the Flame-Monitor EP378 programmer module:

In addition to operation with an external valve proving device, the EP378 provides low fire start, early spark termination for the spark ignition that is connected to terminal X, and waits indefinitely for the M-D low fire start switch to close before the start of pilot trial of ignition. This programmer model also provides a number of operational characteristics that are selected via the ED510 Keypad/Display. **Dip switches 1 and 2, located on the side of programmer, provide recycle (down) / non-recycle (up) and a 10 second (down) or 15 second (up) main trial for ignition period.**

NOTE: The operating control for the EP378 connects to terminals L1-13. The running interlock circuit (air flow, low water, etc.) connects to terminals 13-P. The proof of closure contacts provided by the valve proving controller connect to terminals 13-3.

The following is a list of the programmable functions associated with the EP378 Programmer Module:

- Selectable purge (selectable from 30 seconds to 37 minutes - default setting is 30 seconds).
- Prove the operation of the 13-P Running Interlock Circuit at start - default is NO.
- Terminal 6 operation - Interrupted / Intermittent operation of pilot valve - default is intermittent.
- Purge Count method, UP or DOWN - default is down.
- Selectable Post Purge Timing of 1, 15, 30, or 60 seconds - default is 15 seconds.

OPERATOR & SYSTEM INTERFACE

Local interface to the Phoenix scanner is via a pushbutton keypad and information LEDs. Local interface to the InSight scanner is via a keypad and alpha-numeric display. These provide continuous indication of flame signal, flame relay status, scanner status as well as selected mode of operation. Simplified keystroke routines are used for set up and can be completed in seconds. For remote interface, outputs are provided for fault relay and 4 to 20mA flame strength, in addition to the flame signal connection for the Fireeye programming controller.

PHOENIX WIRING DIAGRAM

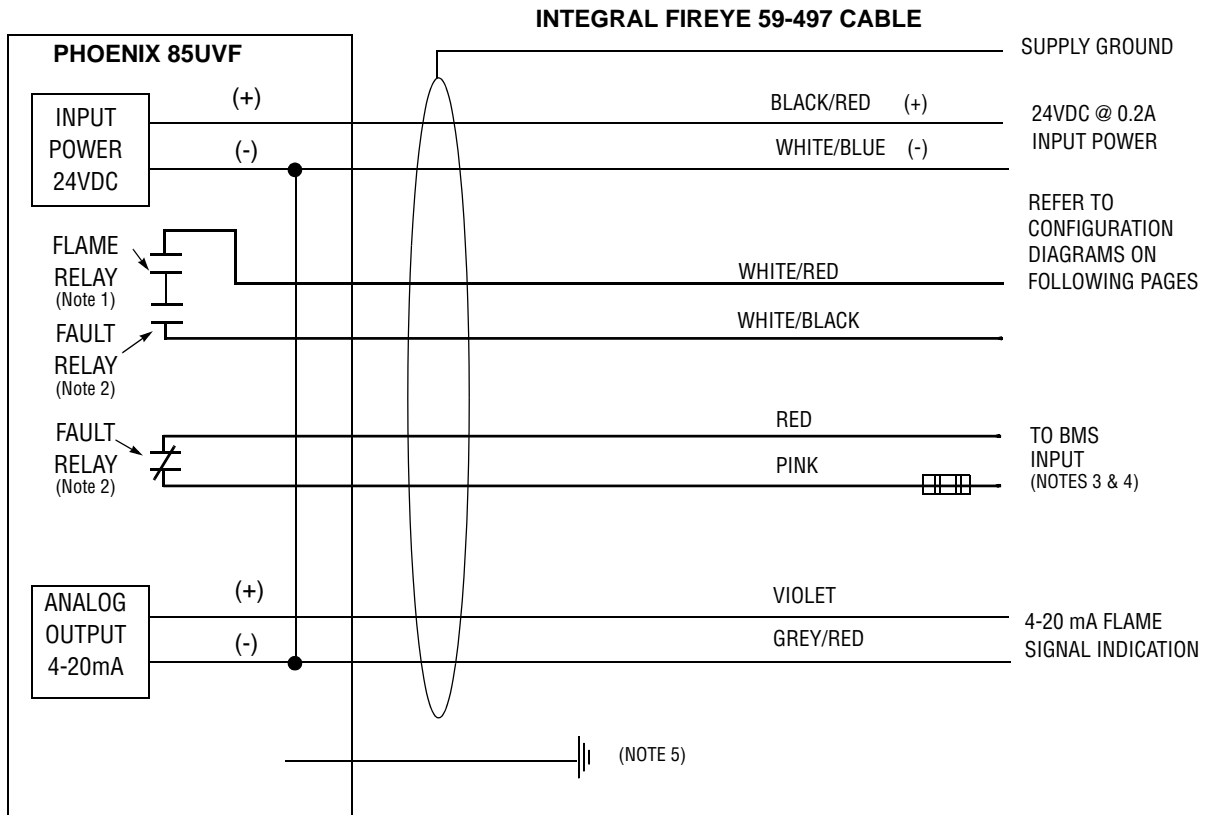

Notes:

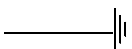
1. Flame relay contacts are shown in the de-energized (no flame condition)
2. Fault relay contacts are shown in de-energized (fault) condition
3. BMS = Burner Management System (by others). Do not use Grey/Red as 24 volt ground
4. External 2.0 Amp fuses recommended
5. A safety ground screw is provided on the scanner end plate. An external ground wire must be installed if line voltage is applied to the relay contacts. 

INSIGHT WIRING DIAGRAM

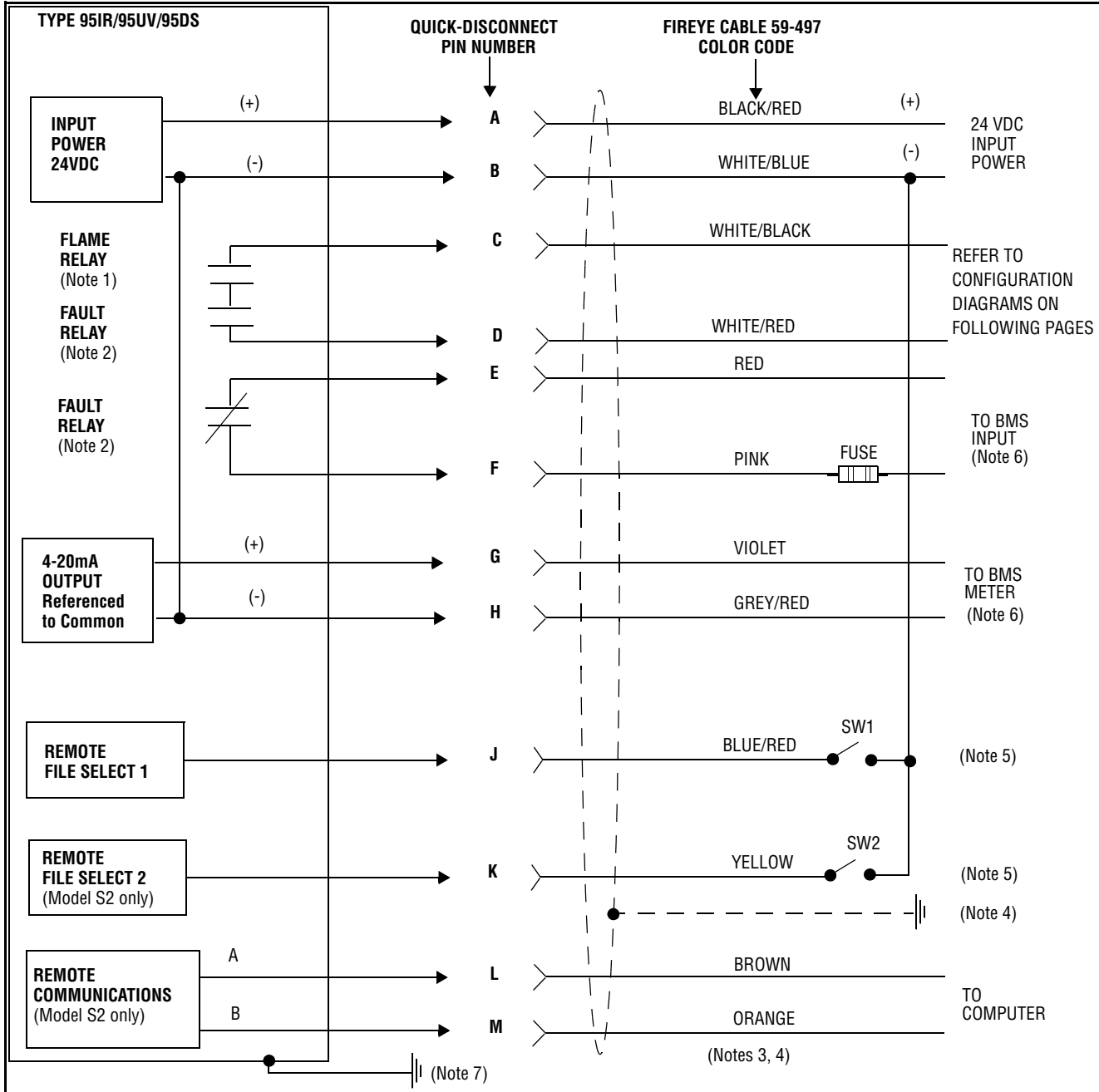

Notes:

1. Flame relay contacts are shown in de-energized (no flame) condition.
2. Fault relay contacts are shown in de-energized (fault) condition.
3. Brown and orange wires are a twisted pair.
4. Connect cable shield to earth ground at power source.
5. With Remote File Select programmed as "LINE", external switches SW1/SW2 (not furnished) will select between two (S1 Models) or four (S2 Models) internal memory files, when connected to 24Vdc (-) supply.
6. External 2.0 Amp fuses recommended.
7. A ground screw is provided on the scanner end plate. An external ground wire must be installed if line voltage is applied to the relay contacts.



SETUP & OPERATION

The Flame-Monitor EP programmers provide a RUN / CHECK switch that halts the programmer during the Pilot Trial for Ignition period. The Flame-Monitor will keep the pilot valve and ignition transformer (terminals 5 and 6) energized during this period. In order for the Phoenix or InSight scanner to provide a contact closure to the Flame-Monitor, it must first be placed in the learn mode during the pilot establishing period. **Refer to bulletin CU-105 for the Phoenix learn procedure and CU-95 for the InSight learn procedure.** During the CHECK mode the Flame-Monitor provides up to 30 seconds of no flame signal to have the PHOENIX or INSIGHT scanner learn the pilot flame signal. After successfully learned the Flame-Monitor can be placed in the RUN mode to advance to the main flame trail for ignition (MTFI) stage.

For the EDC2 amplifier the main flame scanner's output must be proven by the time the program module reaches the AUTO position. The programmer monitors the pilot scanner through PTFI and MTFI and expects the main flame scanner on at AUTO. For the EP178 MTFI is a fixed 15 seconds after PTFI. For the EP378, this time period is dip switch 2 selectable, 10 or 15 seconds. **It is recommended the (S2) Phoenix or InSight scanner be put into the learn mode at the beginning of MTFI.**

If the learn was not successful, the Phoenix and InSight scanner learn mode be allowed to time out prior to the next attempt to learn.

FLAME-MONITOR WITH EP178, EDC1 & 85UVF4-1WR SCANNERS

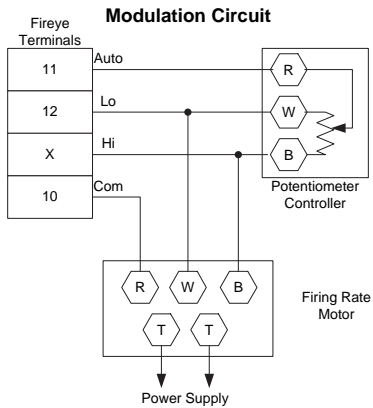
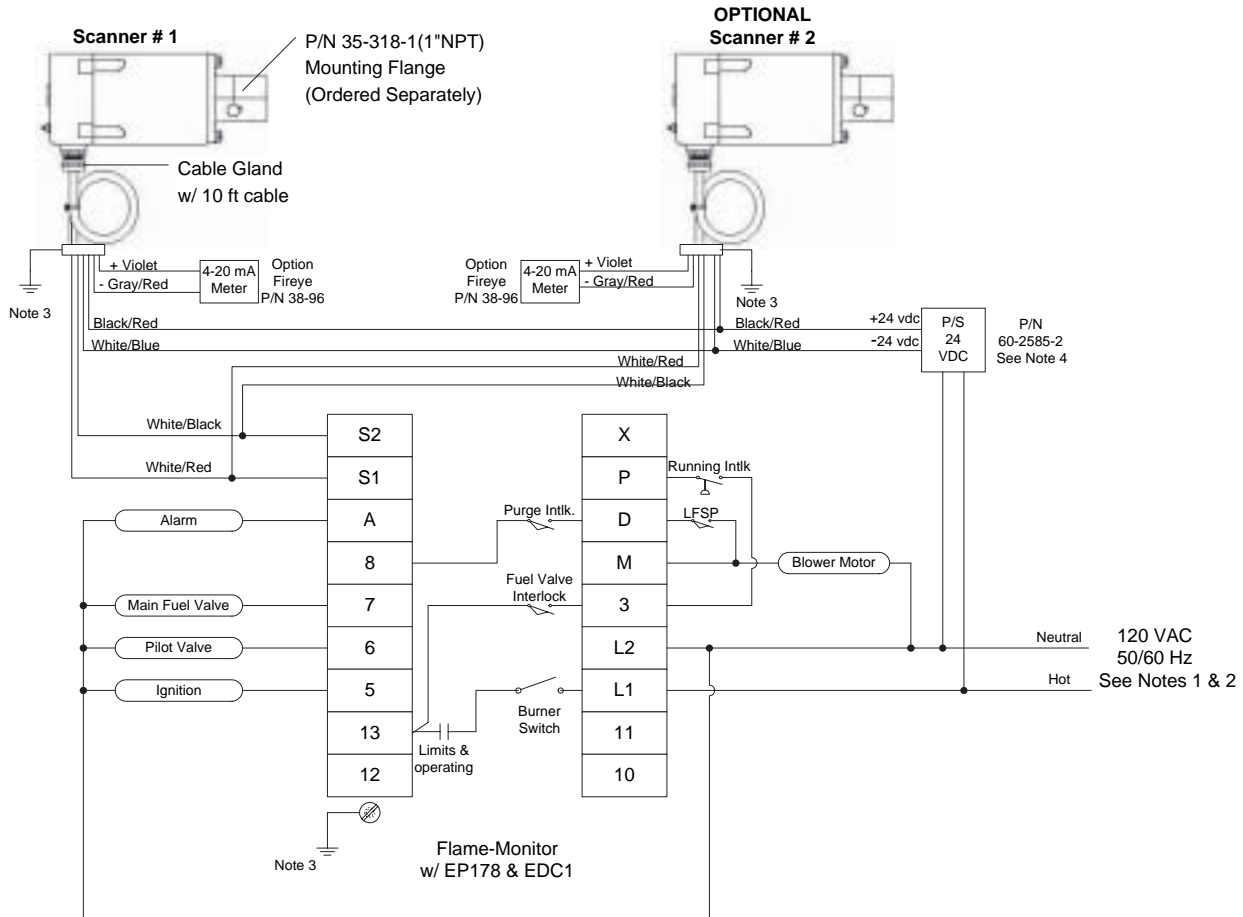

CAUTION: All safety limit switches should be approved as limit controls and should be wired directly in the circuit of the Flame Safeguard control. The use of electronic switches to close interlock circuits may cause erratic operation.

TYPICAL WIRING ARRANGEMENT FOR SPARK IGNITED OIL BURNER

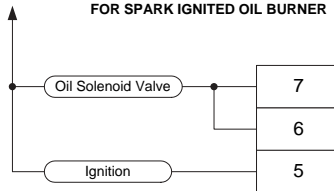

Note 1: Disconnect means & Overload Protection Required

Note 2: All Flame-Monitor Interlock Inputs must be the same AC Phase

Note 3: Scanner shield must be connected to earth ground.

See E-1101 Bulletin for recommended grounding techniques.

Note 4: 24 VDC supply must be powered from same mains supply as E110

Note 5: InSight scanners may be used in place of Phoenix scanners

Flame-Monitor with EP178, EDC1 & INSIGHT scanner with 59-497-020xx-WR CABLE

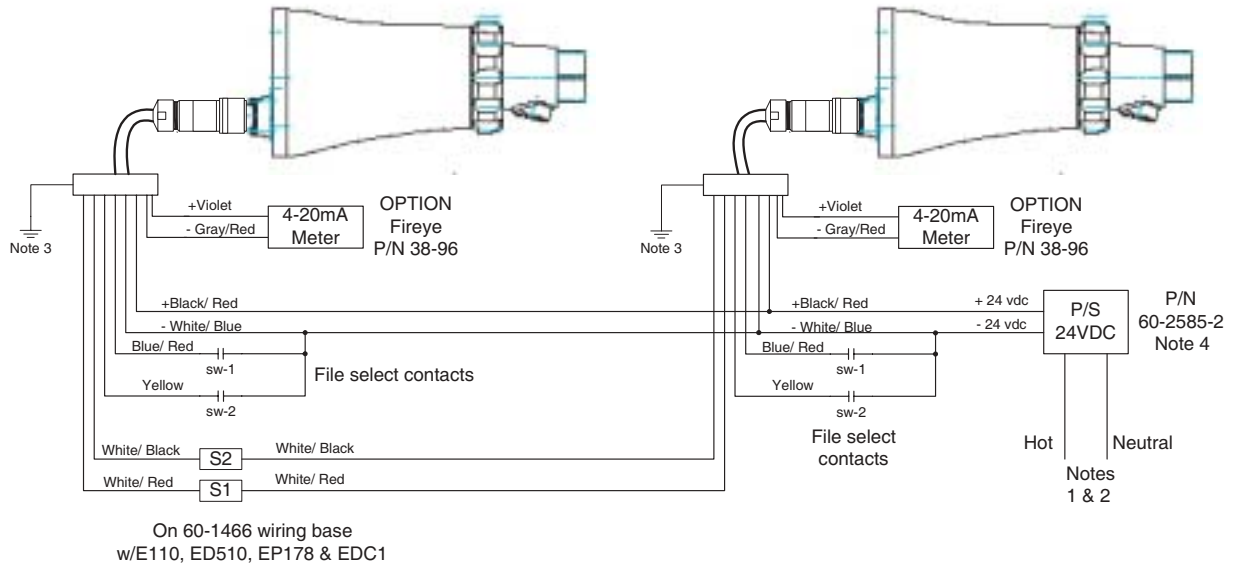

- Note 1: Disconnect means & overload protection required
- Note 2: All Flame-Monitor interlocks input must be from the same AC phase
- Note 3: Scanner shield must be connected to earth ground
- Note 4: 24 VDC supply must be powered from same main supply as E110

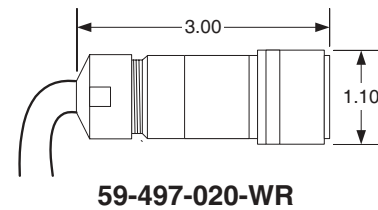
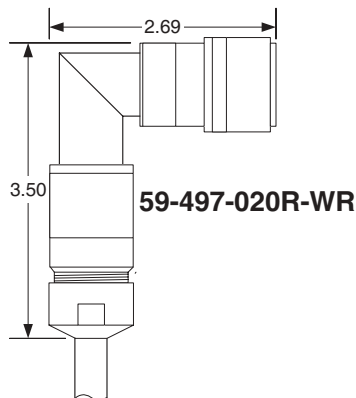
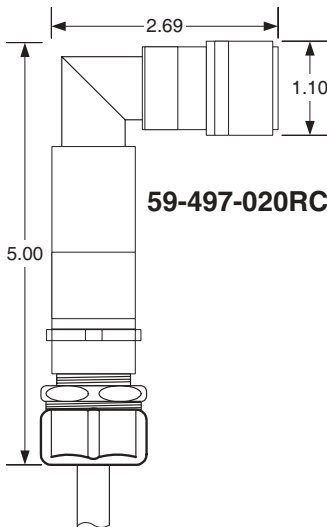
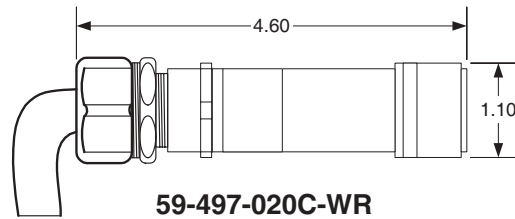



FLAME-MONITOR WITH EP378, EDC1 & 85UVF4-1WR SCANNERS

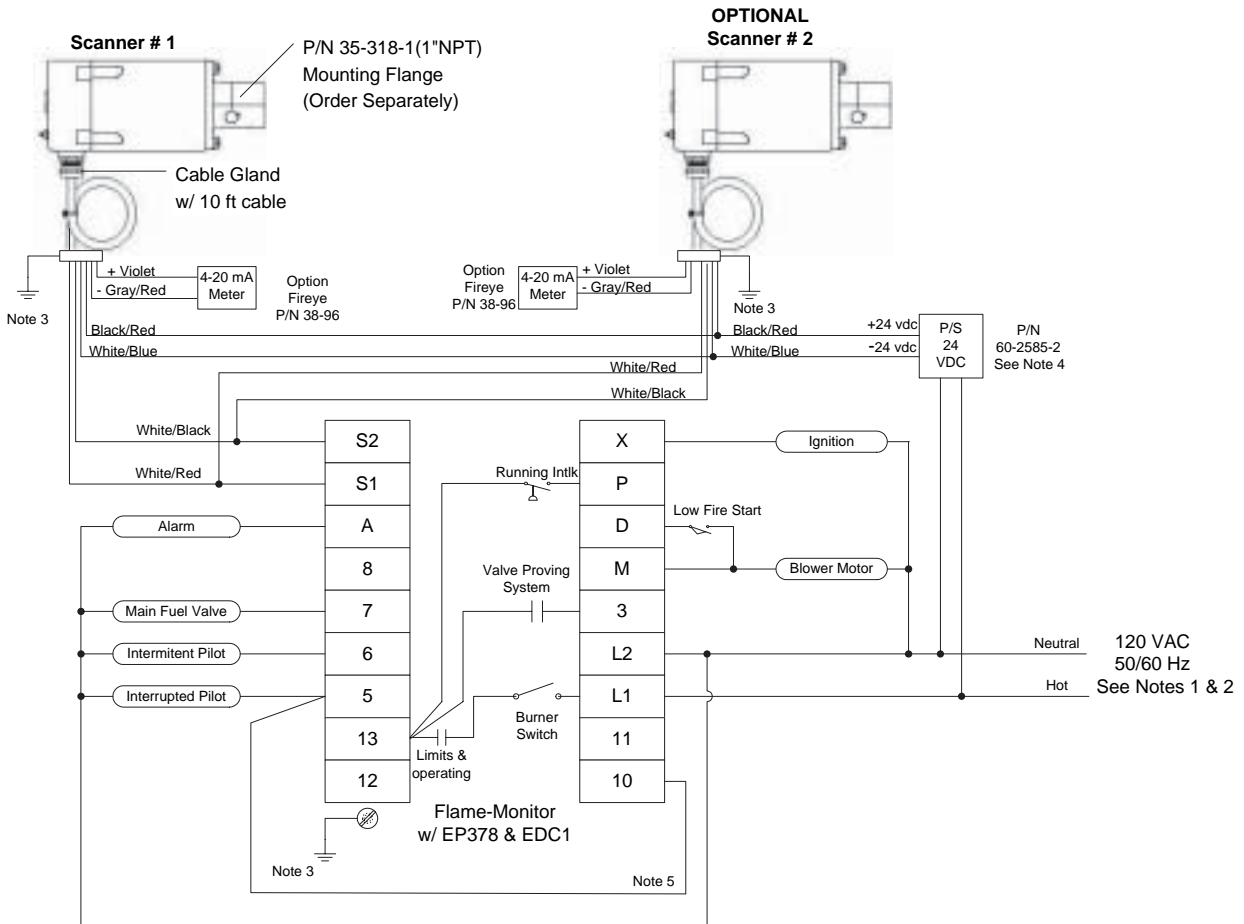

TYPICAL WIRING ARRANGEMENT FOR SPARK IGNITED OIL BURNER

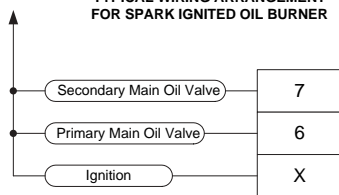

CAUTION: All safety limit switches should be approved as limit controls and should be wired directly in the circuit of the Flame Safeguard control. The use of electronic switches to close interlock circuits may cause erratic operation.

Note 1: Disconnect means & Overload Protection Required

Note 2: All Flame-Monitor Interlock Inputs must be the same AC Phase

Note 3: Scanner shield must be connected to earth ground.

See E-1101 Bulletin for recommended grounding techniques.

Note 4: 24 VDC supply must be powered from same mains supply as E110

Note 5: The jumper 10-5 must be installed for use of Terminal "X"

Note 6: InSight scanners may be used in place of Phoenix scanners

FLAME-MONITOR WITH EP378, EDC2 & 85UVF4-1WR SCANNERS

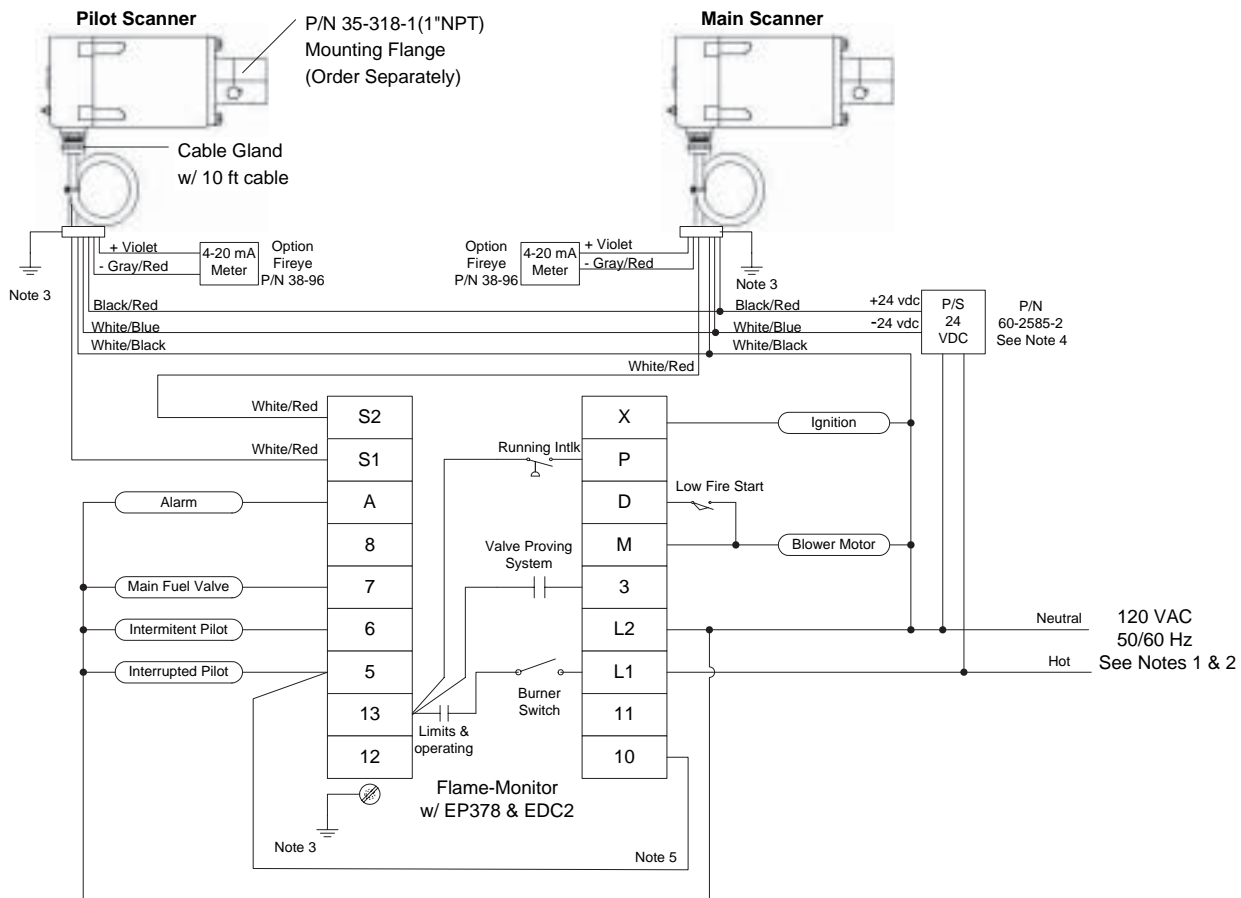

TYPICAL WIRING ARRANGEMENT FOR SPARK IGNITED OIL BURNER

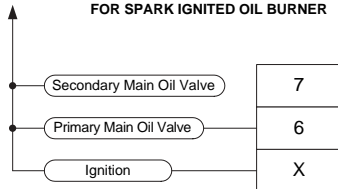

CAUTION: All safety limit switches should be approved as limit controls and should be wired directly in the circuit of the Flame Safeguard control. The use of electronic switches to close interlock circuits may cause erratic operation.

- Note 1: Disconnect means & Overload Protection Required
- Note 2: All Flame-Monitor Interlock Inputs must be the same AC Phase
- Note 3: Scanner shield must be connected to earth ground.
See E-1101 Bulletin for recommended grounding techniques.
- Note 4: 24 VDC supply must be powered from same mains supply as E110
- Note 5: The jumper 10-5 must be installed for use of Terminal "X"
- Note 6: InSight scanners may be used in place of Phoenix scanners





NOTICE

When Fireeye products are combined with equipment manufactured by others and/or integrated into systems designed or manufactured by others, the Fireeye warranty, as stated in its General Terms and Conditions of Sale, pertains only to the Fireeye products and not to any other equipment or to the combined system or its overall performance.

WARRANTIES

FIREEYE guarantees for *one year from the date of installation or 18 months from date of manufacture* of its products to replace, or, at its option, to repair any product or part thereof (except lamps, electronic tubes and photocells) which is found defective in material or workmanship or which otherwise fails to conform to the description of the product on the face of its sales order. **THE FOREGOING IS IN LIEU OF ALL OTHER WARRANTIES AND FIREEYE MAKES NO WARRANTY OF MERCHANTABILITY OR ANY OTHER WARRANTY, EXPRESS OR IMPLIED.** Except as specifically stated in these general terms and conditions of sale, remedies with respect to any product or part number manufactured or sold by Fireeye shall be limited exclusively to the right to replace or repair as above provided. In no event shall Fireeye be liable for consequential or special damages of any nature that may arise in connection with such product or part.



TM FIREEYE™
3 Manchester Road
Derry, New Hampshire 03038 USA
www.fireeye.com

133-674
MAY 26, 2006
Supersedes Jan. 23, 2006