

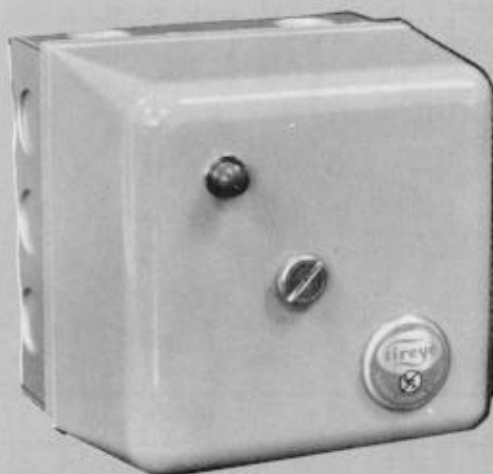

# UVM 6 Flame Safeguard Control



Fireeye M Series Controls



45UV3



UV1B



UV-1A



UV-2

UV SCANNERS

## DESCRIPTION

Fireeye UVM6 Control provides automatic ignition and flame safeguard control for commercial sizes of heating and process burners using gas and/or light oil fuels.

Flame monitoring is accomplished by miniature UV scanners.

Plug-in purge timer cards for use with the UVM6 provide selectable 5-7-30-60-90 second prepurge. A circuit is provided, for an air flow switch to prove air flow during the prepurge and throughout the entire firing cycle.

In the event of ignition failure, or following a safety shutdown, the lockout switch trips, activating an alarm circuit. Manual reset is required. A detailed description of the control's function may be found on Page 6. Test jacks are provided to permit flame signal measurement during operation. A "check-run" switch is provided to assist in testing size and stabilization of pilot in conjunction with the U.V. detector.

The UVM6 control incorporates a safety checking circuit that is operative on each start. If flame (real or simulated) is detected prior to a start or during the purge, the fuel valves will not be energized, and the unit will lockout.

## SPECIFICATIONS

### Supply:

120 V (min. 102, max. 132) 50/60 Hz.

### Ambient Temperature Limits:

	Max.	Min.
Control UVM6	125F	-40F
Scanner UV1A, UV1B, UV2, 45UV3	200F	-40F

### Flame Failure Response Time

UVM6 ..... 4 seconds maximum  
 Trial for Ignition Selectable: Determined by MT timing card selection.

### Power Consumption

5.4VA (Operating)

### Shipping Weight (Approx.)

5 lbs.

### Approvals:

Canadian Standards Association

## LOAD RATINGS

Fireye Term.	Typical Load	Maximum Rating at 120V 60 Hz
3 or 4 Individual or combined	Pilot valve(s) and Ignition Transformer(s)	125VA pilot duty (solenoid valve) plus 250VA (Transformer)
5	Main fuel valve(s)	125VA pilot duty (solenoid) or 25VA pilot duty (solenoid) and 400VA (opening) motorized
8	Motor or contractor	Motor normally energized and deenergized by the operating control whose rating must be suitable. Terminal 8 rated to deenergize 9.8 FLA, 58.8 LRA, on safety lockout.
A	Alarm	50VA, pilot duty

# FIREYE DIVISION

ELECTRONICS  
CORPORATION  
OF AMERICA

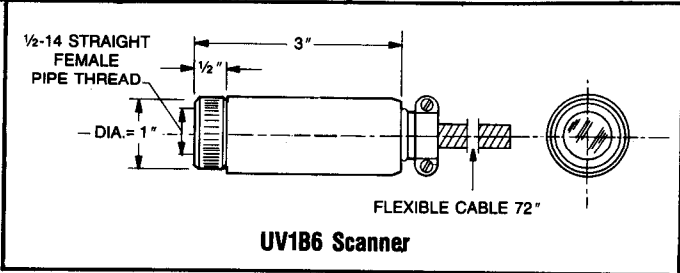
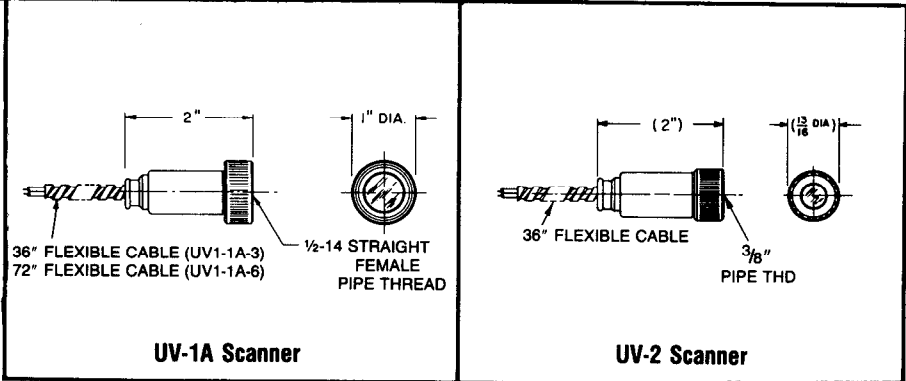
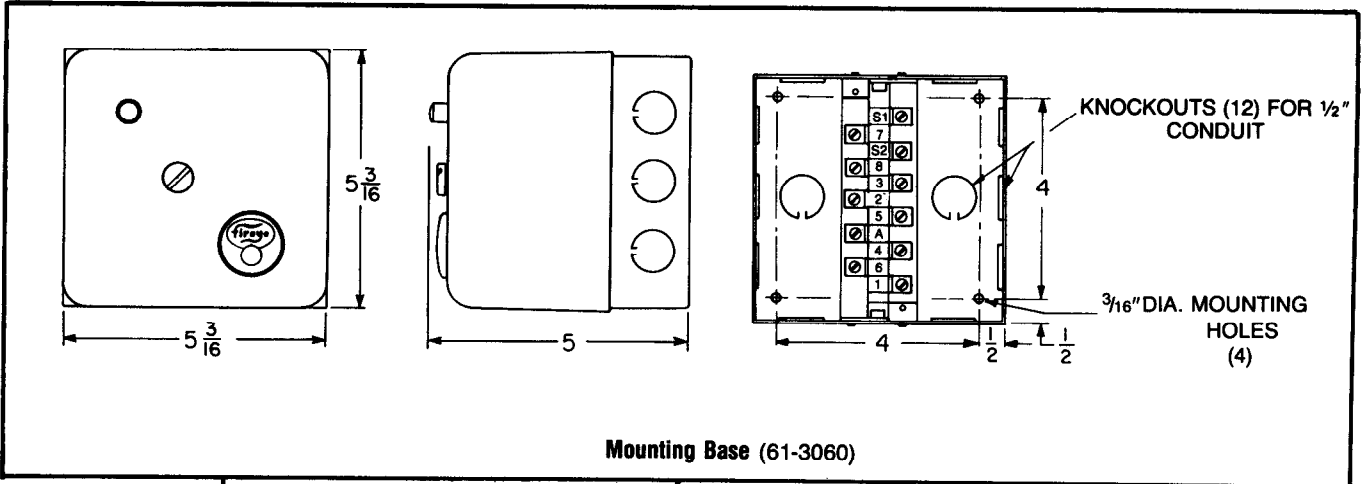

<b>UV SYSTEM Consisting of:</b>	
<b>Control</b> UVM6	
<b>Purge Timing Card for M2, M3 or M5</b>	
MT 55	( 5 second purge, 5 second trial for ignition)
MT 74	( 7 second purge, 4 second trial for ignition)
MT 304	(30 second purge, 4 second trial for ignition)
MT 305	(30 second purge, 5 second trial for ignition)
MT 710	( 7 second purge, 10 second trial for ignition)
MT 904	(90 second purge, 4 second trial for ignition)
MT 3010	(30 second purge, 10 second trial for ignition)
MT 6010	(60 second purge, 10 second trial for ignition)
MT 9010	(90 second purge, 10 second trial for ignition)
<b>UV Scanner</b>	
UV1A3	- 1/2" mount 3' cable
UV1A6	- 1/2" mount 6' cable
UV1B3	- 1/2" mount 3' cable
UV1B6	- 1/2" mount 6' cable
UV2	- 1/8" mount, cast alum. housing, 8' wire
45UV3	- 3/4" mount, cast alum. housing, 8' wire
UV2	- 3/8" mount, 3' cable
<b>Wiring Base</b>	
61-3060 Closed wiring surface mounting	
61-5042 Open wiring base cabinet mounting	

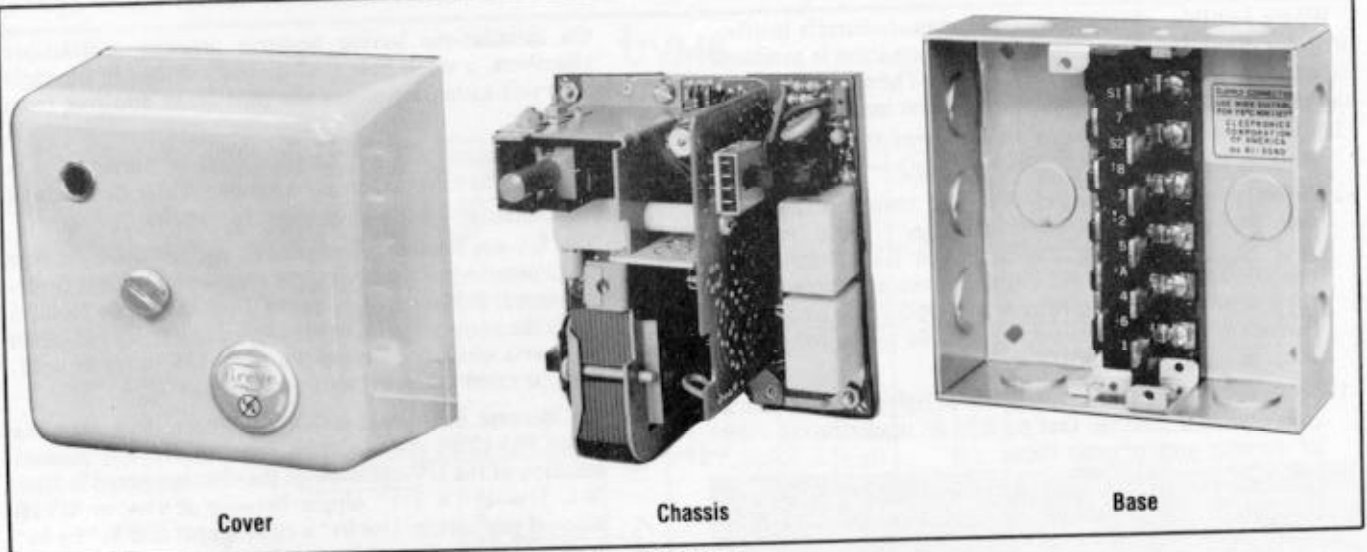

FIGURE 1

UVM6 CHASSIS ARRANGEMENT

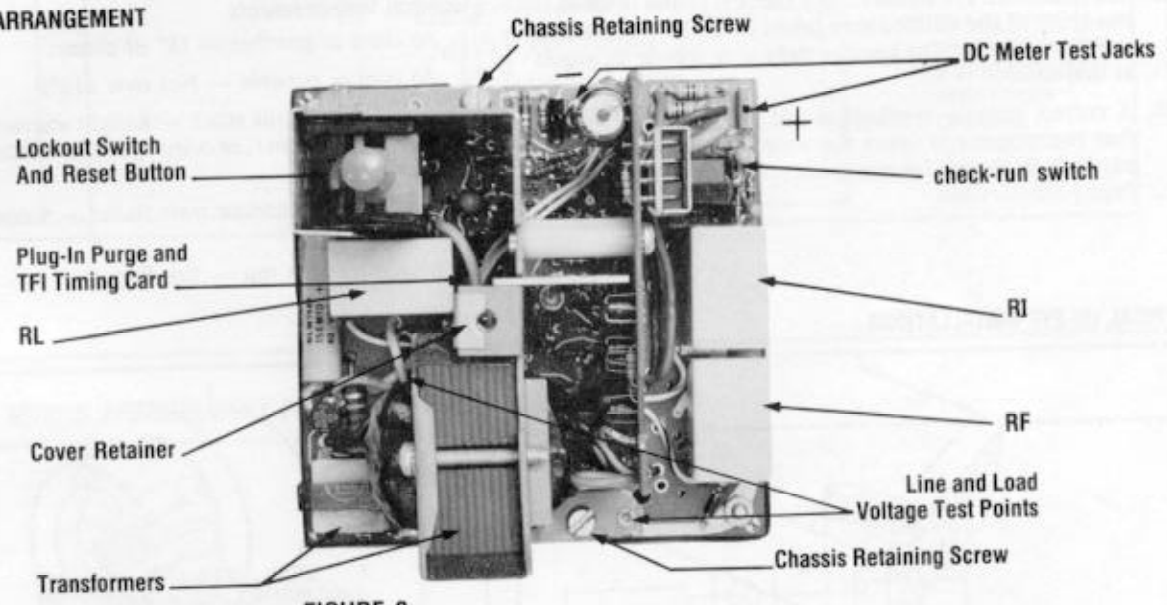

FIGURE 2

INSTALLATION—CONTROLS AND UV-EYE SCANNERS

**Caution:** Installer must be trained and qualified. Follow the burner manufacturer's instructions, if supplied. Otherwise, proceed as follows:

**Control**  
Mount the control base on the burner or on a panel. The location selected should be free from excessive vibration and within the specified ambient temperature rating. The base may be mounted in any angular position.

All wiring should comply with applicable electrical codes, regulations and local ordinances. Circuit recommendations are provided on Page 5. Consult the factory for assistance with non-standard applications.

The control chassis is retained on the base with two screws which should be securely tightened.

**Caution:** Turn off the power when installing or removing the control chassis.

Wiring of UV Scanners

The UV1A and UV1B Scanners are supplied with 36" or 72" of flexible cable. The UV2 Scanner is supplied with 36" of flexible cable. If it is necessary to extend the scanner leads, the following instructions apply: Scanners without armor cable should be wired using metal cable or conduit.

1. Selection of wire
  - a. Use #14, 16 or 18 wire with 75C, 600 volt insulation for up to 200 foot distance (approximately 20% signal loss at 100 feet, 40% loss at 200 feet.)
  - b. Use shielded wire (Belden 8254-RG-62 Coax Cable or equal) for each scanner wire up to 500 feet (max).
  - c. Asbestos insulated wire should be avoided.
  - d. Multiconductor cable is not recommended without prior factory approval.
2. Installation of extended wiring
  - a. For runs up to 10 feet (max.) the scanner leads may be run in a common conduit with other wires.
  - b. For runs over 10 feet the scanner leads must be installed in a separate conduit.
  - c. Multiconductor cable is not recommended without prior factory approval.
3. Multiple scanner installations
  - a. The wiring from multiple UV scanners may be installed in a common metallic conduit.
  - b. Multiconductor cable is not recommended without prior factory approval.
4. High voltage ignition wiring should not be installed in the same conduit with flame detector wires.

## 4 UV Scanner Mounting

Where possible, obtain the burner manufacturer's instructions for mounting the scanner. This information is available for most standard burners manufactured. The scanner mounting must comply with the following general instructions:

1. Locate the scanner within 18 inches of the flame to be monitored, closer if possible.
2. Select a scanner location that will remain within the ambient temperature limits of the UV-eye scanner (212°F). If cooling is required, use (a) an insulating coupling (Fireye part #35-69) to reduce conducted heat; (b) a window coupling (Fireye part #60-1257) to seal off furnace or burner pressure; (c) cooling air to reduce the scanner sight pipe temperature.
3. Mount rigidly a short length (4" to 8") of 1/2" or 3/8" black iron pipe in a position that permits an unobstructed view of the pilot and/or main flame.
4. **Caution:** The scanner must not sight the spark directly or any part of the burner that can reflect the spark back to the scanner.
5. The maximum UV signal from a flame is found in the first one-third of the visible flame taken from the point where the flame begins. The scanner sight pipe should be aimed at this area.
6. A correct scanner application will not see a pilot flame that is too small to ignite the main flame reliably. Note particularly the test for minimum pilot that is described on Page 7.

7. On installations having negative pressure combustion chambers, a small hole (1/8" or 3/16") drilled in the sight pipe will assist in keeping the pipe clean and free from smoke.
8. Two scanners may be installed on one burner if it is necessary to view two areas to obtain reliable detection of the flame. They should be wired in parallel.
9. The UV-eye scanner is designed to seal off the sight pipe up to pressures of 1 psi when the scanner lock nut is firmly tightened. Pressures in excess of 1 psi should be blocked from the scanner. A quartz lens coupling (Part #60-1290) or quartz window coupling (Part #60-1257) may be used. Each is rated from -3 to +100 psi max.
10. To increase scanner sensitivity, a quartz lens coupling (Part #60-1290) may be used. The quartz lens permits location of the UV-eye at twice the distance noted in Item B-1. Use 1/2" x 1 1/2" nipple between UV1A or UV1B scanner and union. Use 3/8" x close nipple and 1/2" by 3/8" bushing on UV-2 applications.

### General Requirements

1. As close as possible — 18" or closer.
2. As cool as possible — Not over 212°F.
3. Avoid sighting the spark — Resight scanner, shield between spark and scanner, or orifice to reduce reflected signal from spark.
4. Must see pilot and/or main flame — Scanner view must be unobstructed.
5. Minimum pilot test — See Page 7.

### TYPICAL UV-EYE INSTALLATIONS

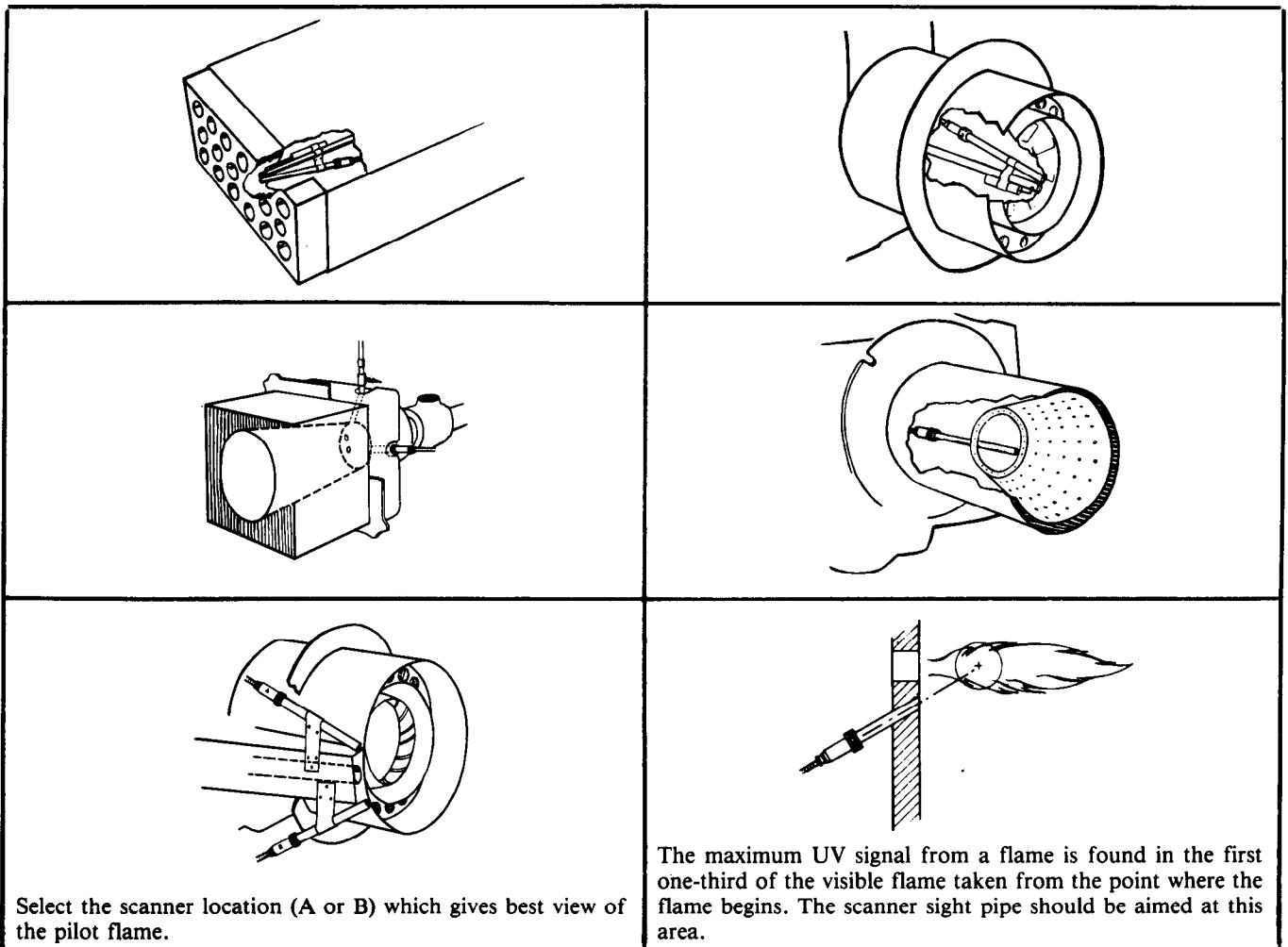

Select the scanner location (A or B) which gives best view of the pilot flame.

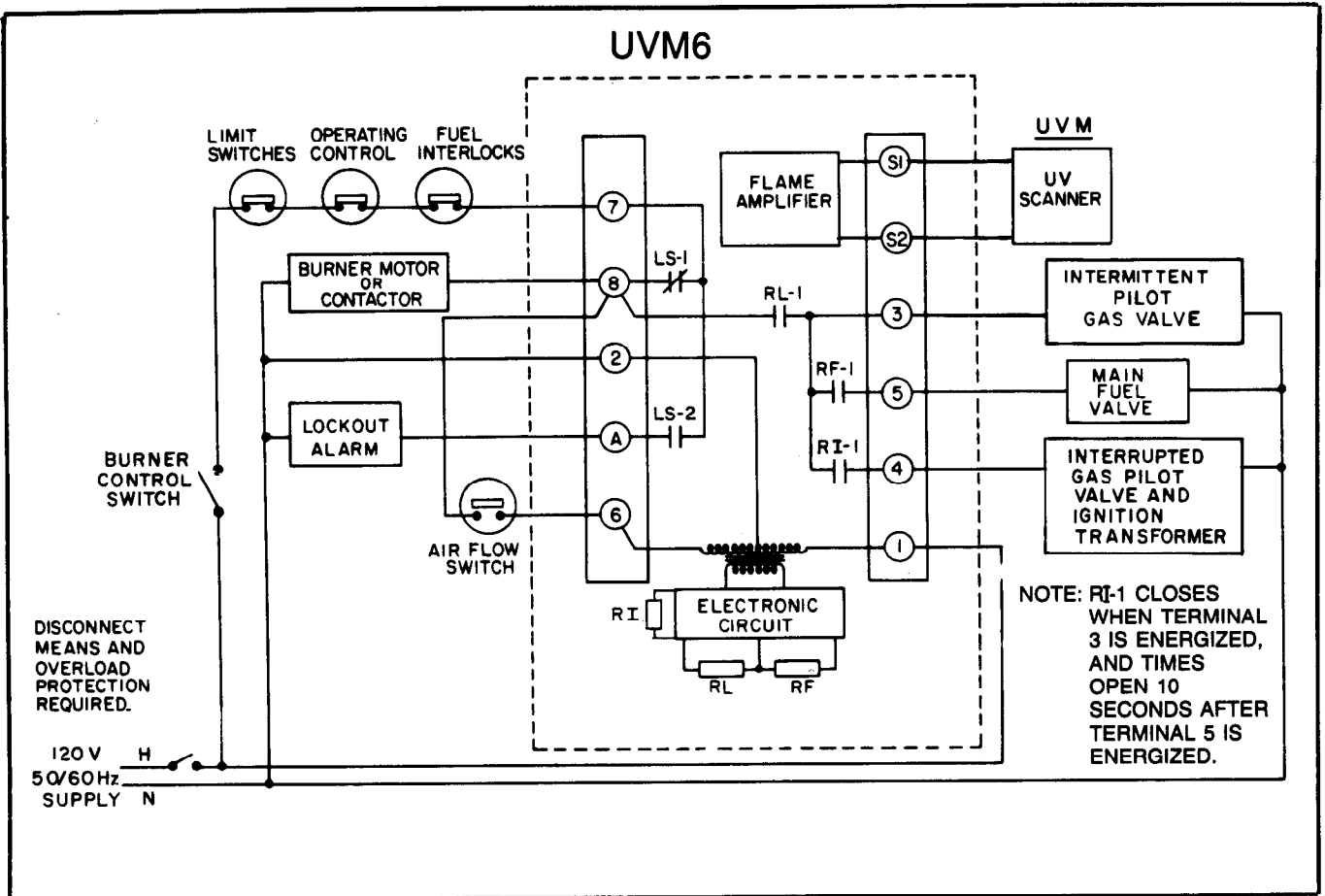

TYPICAL UVM6 WIRING ARRANGEMENT FOR DIRECT SPARK IGNITED BURNER

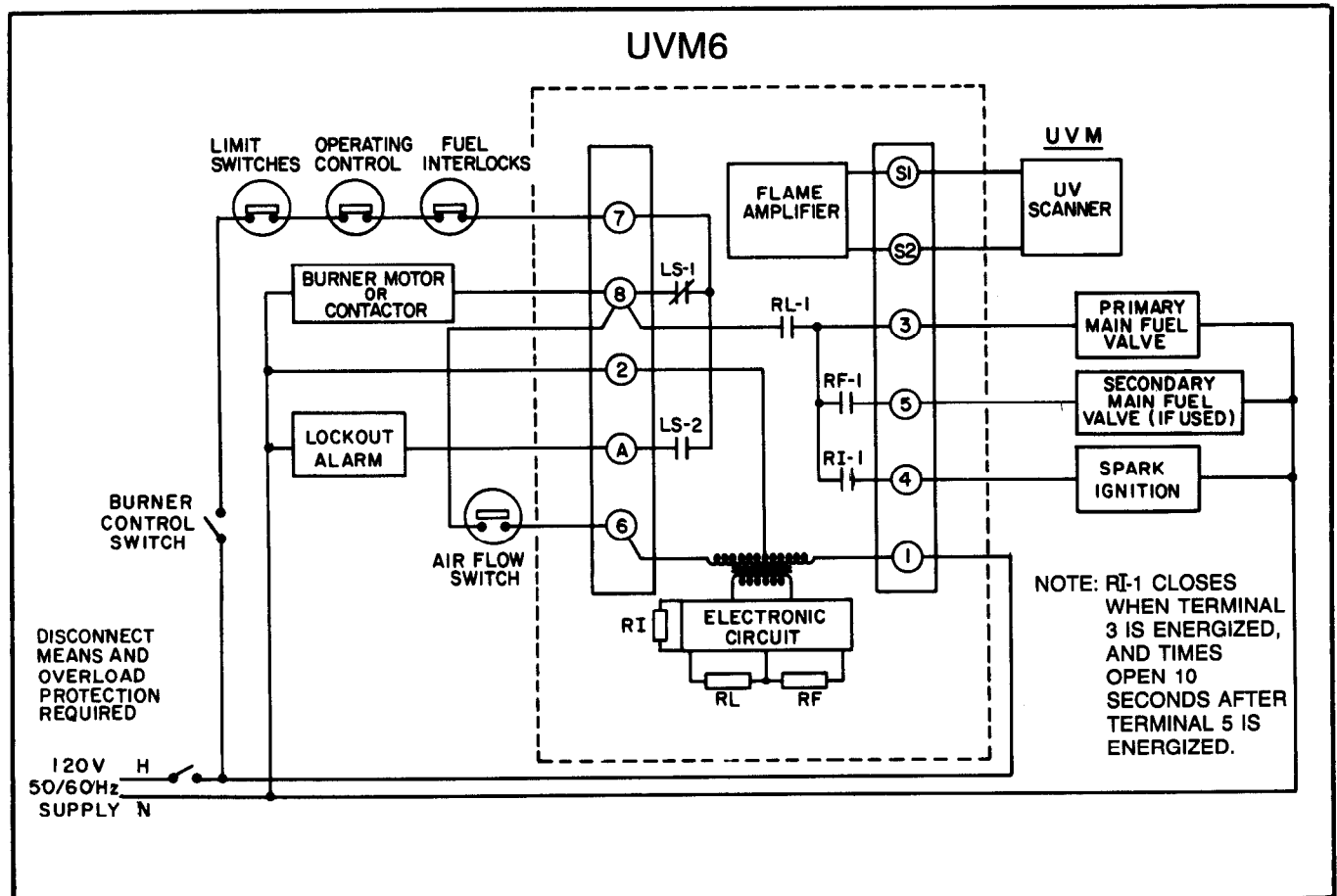

Fireye M6 Series, "recycle" control provides prepurge, ignition and flame safeguard for heating and process light oil or gas fired burners. The UVM6 control also provides non-recycle capability on loss of main flame by removing red jumper as shown below.

Clip out the red wire loop close to circuit board. This converts the control from Recycle to Non-Recycle on loss of main flame. (See figure 4)

The UVM6 control uses UV flame detection and has a 4 sec. (max.) flame failure response and 10 sec. trial for ignition (4 or 5 seconds available). Plug-in circuit cards provide selectable 5-7-30-60-90 second prepurge. (See Page 2)

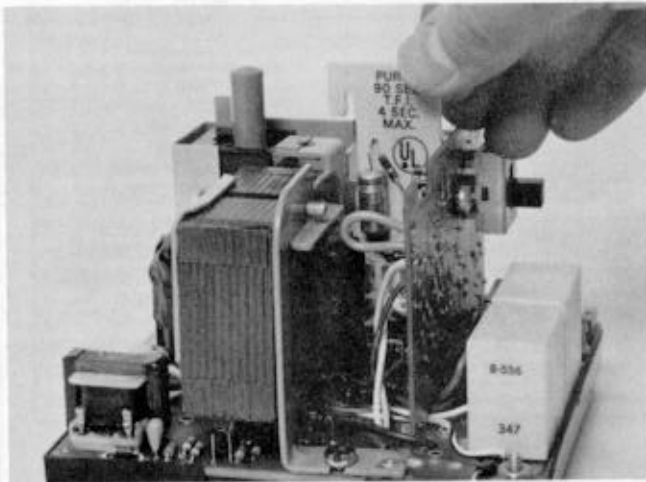

**FIGURE 3**  
INSERTING MT TIMING CARD  
(PURGE TIME AND TRIAL FOR IGNITION)

The typical wiring arrangement illustrated on Page 5 for pilot ignited burners provides the following function:

1. With power applied, and the limit-operating control circuit closed, the burner motor circuit is energized. The air flow circuit closes.
2. Following the selected prepurge period, RL-1 and RI-1 close, energizing Terminals 3 and 4 which powers the pilot gas valve and the spark ignition. A 10 sec. trial-for-ignition (4 or 5 seconds available via MT timing card selection is initiated).
3. When pilot flame is detected, a 6 sec. pilot stabilization period begins followed by RF-1 closing. Ten seconds after RF-1 closes, Terminal 4 is de-energized.
4. When the operating control opens its circuit or if a power failure occurs, the entire system is de-energized.
5. In the event the pilot flame is not detected by the end of trial for ignition period, the pilot gas valve and spark ignition are de-energized. A safety lockout occurs which de-energizes the burner motor and energizes the lockout alarm circuit.
6. In the event of a flame failure during a firing period, the pilot and main fuel valves are de-energized. \*Following the prepurge period, with proven air flow, the pilot gas valve and spark ignition are re-energized and a 10 sec. trial-for-ignition is initiated. (4 or 5 seconds available). If pilot flame is detected, the main fuel valve is energized, the spark ignition and pilot are de-energized. If the pilot flame is not detected during the trial for ignition period, the pilot gas valve and spark ignition are de-energized. A safety lockout occurs which de-energizes the burner motor and energizes the lockout alarm switch.
7. Manual reset is required following any safety lockout.

The typical wiring arrangement illustrated on Page 5 for direct spark ignited burners provides the following functions.

1. With power applied, and the limit-operating control circuit closed, the burner motor circuit is energized. The air flow switch circuit closes.
2. Following the selected prepurge period, RL-1 closes energizing Terminal 3 which powers the primary main fuel valve, and Terminal 4 which powers the spark ignition. A ten second trial for ignition is initiated (4 or 5 seconds available).
3. When primary flame is detected, a 6 second stabilization period begins and RF-1 closes, energizing Terminal 5 which powers the main fuel valve. Ten seconds later RI-1 opens, de-energizing Terminal 4 which shuts off the spark ignition.
4. When the operating control opens its circuit, or if a power failure occurs, the entire system is de-energized.
5. In the event the primary flame is not detected by the end of the trial for ignition period, the primary valve and spark ignition are de-energized. A safety lockout occurs which de-energizes the burner motor and energizes the lockout alarm circuit.
6. In the event of a flame failure during a firing period, all fuel valves are de-energized. \*Following the prepurge period, with proven air flow, the primary main fuel valve and spark ignition are re-energized and a ten second trial-for-ignition period is initiated (4 or 5 seconds available). If flame is detected, the secondary main fuel valve (if used) is energized. The spark ignition is de-energized. If flame is not detected during the trial-for-ignition period, the primary main fuel valve and spark ignition are de-energized. A safety lockout occurs, de-energizing the burner motor and energizing the lockout alarm circuit.
7. Manual reset is required following a safety lockout.

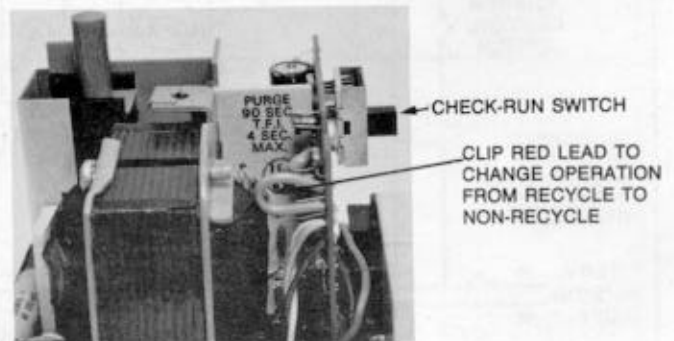

**FIGURE 4**

\*With red jumper clipped, M6 control becomes "non-recycle" on flame failure during a firing cycle. A safety lockout occurs which de-energizes the burner motor and energizes the lockout alarm switch.

## Use of Test Meter

Testing UVM controls requires the use of a test AC-DC multimeter, with a 20,000 ohm/volt DC rating, or a digital meter with 500K input impedance or greater.

With the test meter leads inserted into the test jacks, a steady DC voltage reading of 5 to 6 volts should be obtained when

the controls are detecting flame, and zero volts when no flame is present.

With the test meter on the AC scale, line and load voltages may be measured at the identified test points on the chassis.

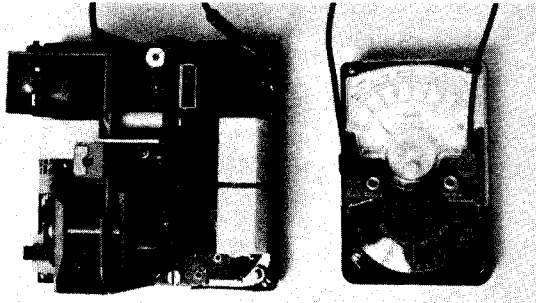

**D.C. TEST JACKS**  
**FIGURE 5**

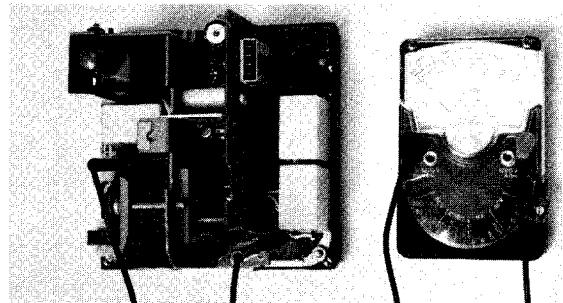

**A.C. LINE AND LOAD VOLTAGES**  
**FIGURE 6**

## Flame Signal Testing

1. Manually shut off the main fuel valve, for a pilot ignited burner or the secondary main fuel valve for a direct spark ignited burner.
2. Set the test meter on the DC scale and insert the meter leads into the test jacks. (If the meter reads backwards, reverse the meter leads.)
3. Initiate a normal startup.
4. When flame is established, the test meter reading should be normal.

5. Inadequate flame signal may be improved by:
  - a. Assure that the flame detector and wiring installation have followed the instructions on Pages 3, 4, and 5.
  - b. Assure that the flame detector is clean and within the ambient temperature limits.
  - c. Assure that the flame is sufficiently large to detect.
  - d. Try a shorter sight pipe, or increase the sight pipe diameter.

## Normal Pilot Flame Test

1. **Caution:** Before making a pilot flame test, manually shut off the fuel supply to the main burner.
2. Place the "Check Run" switch in the "Check" position. See Fig. 4.
3. Turn power on and initiate a normal start-up.
4. Observe the pilot flame signal on the test meter. If the average voltage is below normal, readjust the pilot flame or realign the U.V. Detector.
5. During the pilot flame test and adjustment period, if flame is not detected (in 30 seconds), the control will lockout. To reestablish the pilot flame trial for ignition (TFI), manual reset of lockout switch is required, and a complete repurge is accomplished.

6. When UV flame detection is used, a test is required to verify that UV radiation from the ignition spark is not being detected. To accomplish this, manually shut off both pilot and main fuels. Initiate a normal startup, observe the test meter which should read no more than 1/2 volt D.C. If more than 1/2 volt is observed, realign the U.V. scanner, and/or shield the spark from tab scanner's view.
7. Move "Check Run" switch to the "Run" position, check pilot flame failure response by manually shutting off the pilot fuel and then initiate a normal startup. With no pilot flame present, the control will de-energize the pilot assembly and the end of the trial for ignition interval, and the control will lockout.

## Minimum Pilot Test

**Caution:** The minimum pilot test must be accomplished by a trained and qualified burner technician.

This test insures that the detector will not sense a pilot flame too small to light the main flame reliably. It must be made on each new installation and following repositioning of the flame detector. This procedure should *not* be used on a direct spark ignited burner.

1. Manually shut off the fuel to the main burner.
2. Place the "Check Run" switch in the "Check" position. (See figure 5)
3. Connect a test meter to test jacks.
4. Initiate a normal start up.
5. Reduce the fuel to the pilot until D.C. voltmeter reads 3.5 volts. This is minimum pilot.

6. Slowly turn on the main fuel and insure that the main flame lights off promptly and normally.

**7. Caution:** If light off is delayed, shut off the power to the installation. Realign the detector so that pilot flame detection requires a larger pilot flame. Repeat this test until main flame lights reliably with minimum pilot.

8. After the minimum pilot test is completed satisfactorily, increase the pilot flame to normal size.

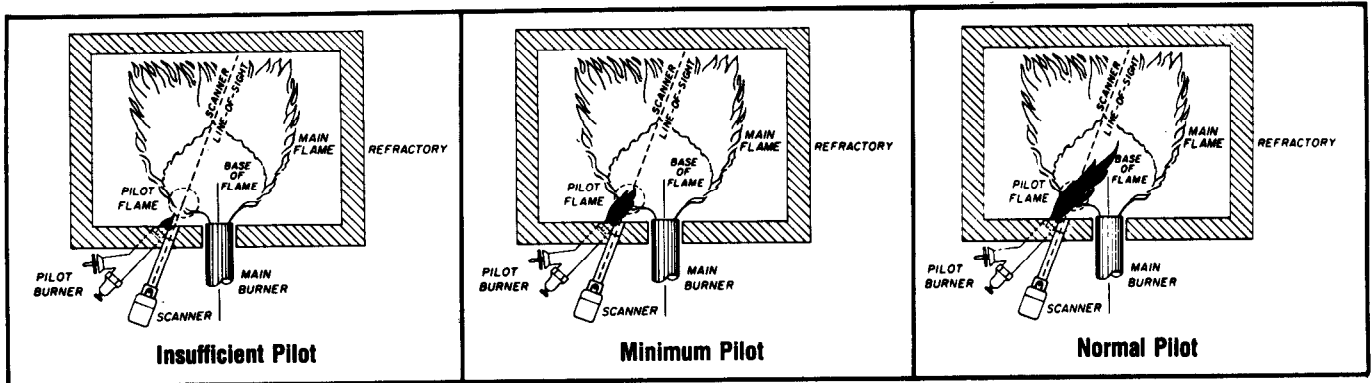

### Flame Failure Test

- Temporarily connect spark ignition and pilot valve to Terminal 3.
- Initiate a normal start-up.
- Manually shut off all fuel and observe the loss of flame signal on the test meter.
- If flame signal does not reduce to zero within the flame failure response time of the control, verify that the UV flame detector is not actuated by the spark. If spark is

detected, a metallic shield or relocation of the UV scanner sight pipe, is required.

- When test is completed, reconnect the spark ignition to Terminal 4.

### Recommendation

**Periodic Safety Check:** Test the complete flame safeguard system at least one a month. This test should verify flame failure safety shutdown and positive fuel cutoff when the fuel valve is de-energized.

### MAINTENANCE

**UV-eye Scanner:** The UV tube must be kept clean. Use a clean cloth with detergent as often as operating conditions require.

### ROTATION

It is recommended that units purchased as spares be rotated periodically, so that each unit will be placed in operation at least every 90 days.

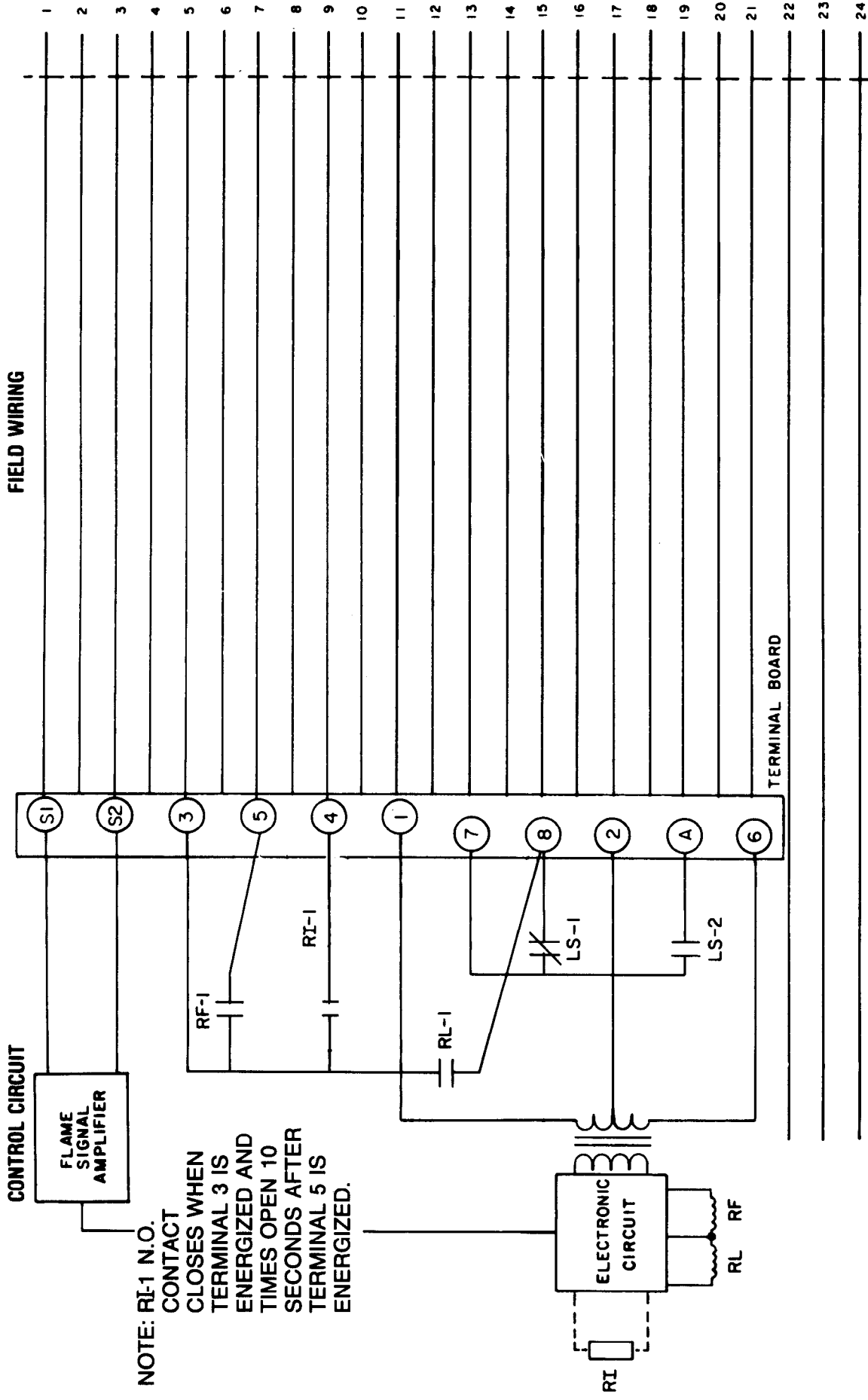

UVM6

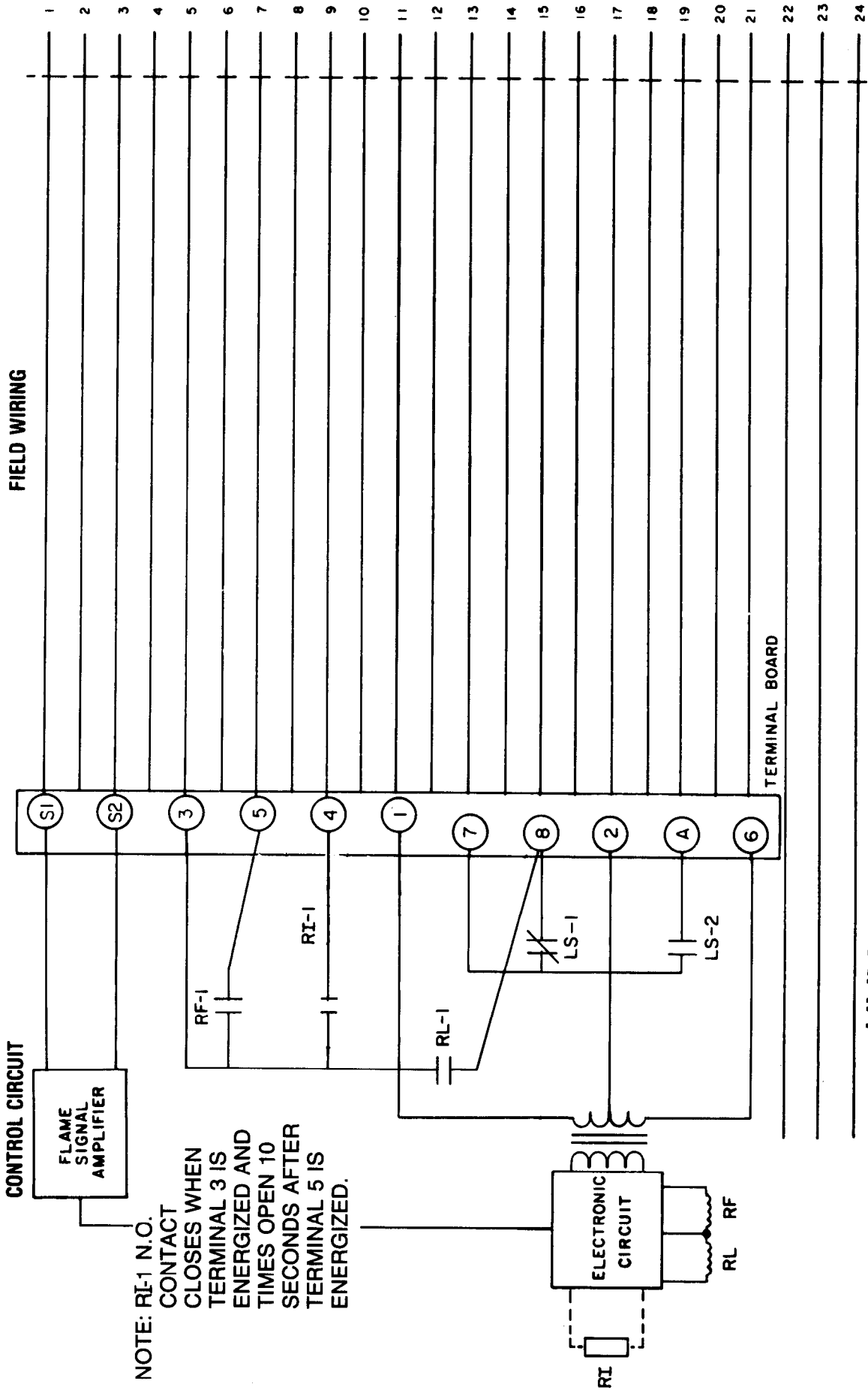

UVM6

## WARRANTIES, EXCLUSIVE REMEDIES, AND LIMITATION OF DAMAGES

ECA guarantees for one year from the date of shipment of its product to replace or, at its option, to repair any product or part thereof (except lamps, electronic tubes and photocells) which is found defective in material or workmanship or which otherwise fails to conform to the description of the product on the face of its sales order.

THE FOREGOING IS IN LIEU OF ALL OTHER WARRANTIES AND ECA MAKES NO WARRANTY OF MERCHANTABILITY OR ANY OTHER WARRANTY, EXPRESS OR IMPLIED.

EXCEPT AS SPECIFICALLY STATED IN ECA'S GENERAL TERMS AND CONDITIONS OF SALE, REMEDIES WITH RESPECT TO ANY PRODUCT OR PART MANUFACTURED OR SOLD BY ECA SHALL BE LIMITED EXCLUSIVELY TO THE RIGHT TO REPLACEMENT OR REPAIR F.O.B. MANCHESTER, NEW HAMPSHIRE, AS ABOVE PROVIDED. IN NO EVENT SHALL ECA BE LIABLE FOR CONSEQUENTIAL OR SPECIAL DAMAGES OF ANY NATURE WHICH MAY ARISE IN CONNECTION WITH SUCH PRODUCT OR PART.



### ELECTRONICS CORPORATION OF AMERICA FIREYE DIVISION

265 Winter Street, Waltham, MA 02154 • Tel.: 617-466-8000 • Telex: 92-1413

AREA OFFICES: Atlanta • Boston • Chicago • Cleveland • Houston • Los Angeles • New York • Philadelphia • San Francisco  
SUBSIDIARIES: ECA (Canada) LTD., 520 Kipling Avenue, Toronto, Ontario M8Z 5E5 416-255-9123 • Montreal • Vancouver

• ECA (Great Britain) LTD; London • ECA European Division, Brussels, Dusseldorf

DISTRIBUTORS: Located in major countries throughout the world

Printed in U.S.A.