

R9008

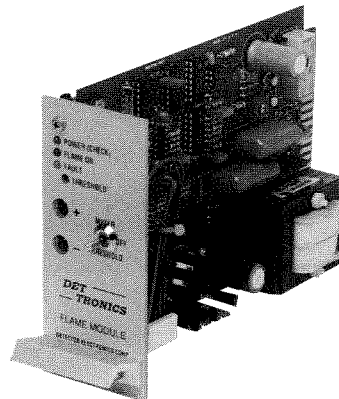

R9108M

R9008M/R9108M/C9508M INSTRUCTION MANUAL

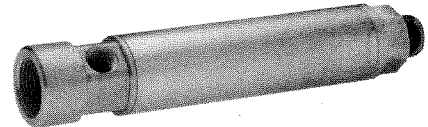

C9508M

SYSTEM APPLICATION AND DESCRIPTION

The Fireye C9508M Ultraviolet Flame Scanner responds to ultraviolet (W) radiation wavelengths between 1850 and 2650 angstroms, which are emitted by most gaseous and liquid fuel flames. It features a low profile design that mounts directly on a 1-inch sight pipe and a plug-in self-checking sensor module for easy maintenance. It comes equipped with either a military style connector for quick electrical connection or 10-foot lead-wires.

The Fireye R9008M (Panel-mounted) or R9108M(Rack-mounted) Controller monitors signals from one C9508M Flame Scanner and provides relay switching within one or four seconds of flame loss (jumper selectable). Each controller has an adjustable flame on threshold to allow increased application flexibility. The flame signal (0-10 VDC) test jacks on the controller front panel meter and at the controller wiring terminals allows for easy monitoring of the flame signal. Front panel LEDs indicate flame presence, fault condition and power (power LED flicks off every 5 to 7 seconds indicating that self-checking is occurring). The flame on threshold potentiometer and gain select switches for adjusting the flame signal amplitude are adjustable through the front panel of either the R9108M or R9008M Controller.

FEATURES

- **Low Profile Scanner For Gas and Light Oil Applications.** Scanner has outside diameter of 1-3/4 inches and mounts directly onto a 1-inch sight pipe.
- **Easy Maintenance.** All scanner electronic and moving parts are contained in the sensor module which simply plugs in for easy replacement.
- **Assured Operation.** Innovative scanner design provides self-check feature for assured integrity of the scanner while featuring low profile design and easy maintenance.
- **Enhances Discrimination.** Flame on threshold is adjustable at the controller allowing more precise flame discrimination in multibranch or multiburner applications.

SYSTEM OPERATION

The R9108M and R9008M Controllers process signals from one C9508M Flame Scanner and energize the Flame relay in response to flame verification. The front panel of each controller contains three LED status indicators, and output jacks for the voltage measurement of flame signal. The following list summarizes the front panel controls and indicators. Refer to Figure 1.

FIGURE 1.

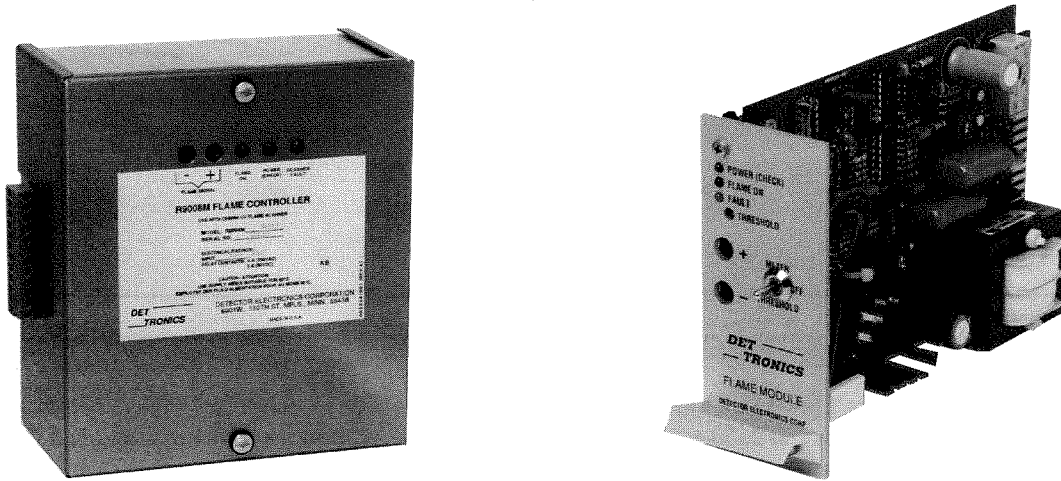

R9008M PANEL MOUNTED

R9108M RACK MOUNTED

POWER (CHECK) LED - Illuminated when power is applied. Goes off during scanner test (approximately 0.5 seconds out of every 5 to 7 seconds).

FLAME ON LED - Illuminated when the flame intensity signal exceeds the flame on setpoint.

FAULT LED - Comes on if the scanner fails self-test.

FLAME THRESHOLD - Adjusts the flame threshold to block background flames and pass the higher flame signal from the desired flame.

Operational Block Diagram

The primary function of the flame safeguard system is to verify the presence of a burner flame. The R9108M/R9008M Controllers monitor the signal from the C9508M Flame Scanner and energize Flame On Relay K1 when the scanner signal exceeds the flame on threshold. At approximately 5 to 7 second intervals, a mechanical light chopper in the scanner blocks the signal from the flame to simulate a flame loss. If response to the simulated flame loss is improper, the Flame On Relay is de-energized and the fault LED comes on.

FIGURE 2.

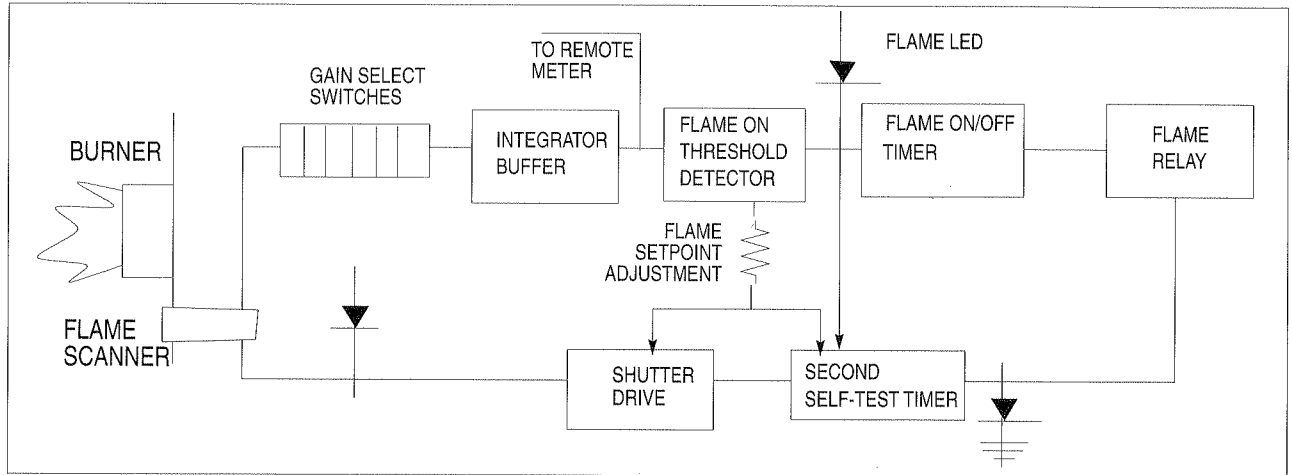

Referring to Figure 2:

- Flame signal from scanner is received by an integrator buffer for processing and generates a flame signal that can also drive an external meter. Note that the gains select switches can be used to adjust the flame signal to a usable level.
- The flame signal is sent to the flame on threshold detector.
 - When the flame signal exceeds the user-adjusted Flame On threshold, the signal is passed to the flame on/off timer.
 - When the flame signal drops below the Flame On threshold, no signal is passed to the timer.
- Flame Relay K1 is energized and the red FLAME LED is illuminated when the flame signal exceeds the adjustable flame on threshold for over 1.5 seconds.

Flame Relay K1 is de-energized within 1 or 4 seconds (jumper selectable - W1 installed = 1 second, W2 installed = 4 seconds) of flame loss.

- Front panel indicators reflect normal system operation when:
 - The green POWER/CHECK LED is illuminated for 4.5 to 6.5 seconds and blinks off for 0.5 second during the scanner self-test.
 - The red FLAME LED is illuminated, indicating that the flame on threshold has been exceeded (K1 is energized if there is no fault condition).
- When the flame signal exceeds the flame on threshold setpoint, the signal is passed to the self-test timer.

If the flame signal does not drop below the minimum flame on threshold setpoint (in response to a successful scanner self-test) on any two successive check cycles, the self-test timer will “time-out” causing relay K1 to de-energize and the FAULT LED to illuminate.

SPECIFICATIONS

C9508M FLAME SCANNER

ELECTRICAL -

C9508M2011 and C9508M2022 (lead-wires): 10 foot non-shielded conductors, insulation rated 600 volts AC at 257°F (125°C) dry.

C9508M2000 - (military connector): 5 pin quick connect plug.

MECHANICAL -

Front (viewing) end mounts directly onto 1-inch NPT sight pipe.

Rear (wiring connector) coupling is one of three models:

C9508M2011 - 3/4-inch NPT connector (internal thread).

C9508M2022 - 25 millimeter connector (internal thread).

C9508M2000 - Military connector.

MATERIAL - Zinc-plated steel.

PURGE AIR REQUIREMENTS -

3 inches water column above furnace pressure.

TEMPERATURE -

Operating -4°F to +185°F (-20°C to +85°C).

Storage: -50°F to +257°F (-46°C to +125°C).

HUMIDITY - 5 TO 95% relative (non-condensing).

NOTE: The C9508M has been successfully tested for operation at temperatures up to +220°F (+105°C), however, operation over +185°F (+85°C) is not covered under warranty. A temperature sensitive label within the detector housing will indicate if the temperature has exceeded +185°F (+85°C). Warranty is void if temperature sensitive label is removed.

DIMENSIONS - See Figure 3.

SHIPPING WEIGHT - 3 pounds.

FIGURE 3. C9508 DIMENSIONS

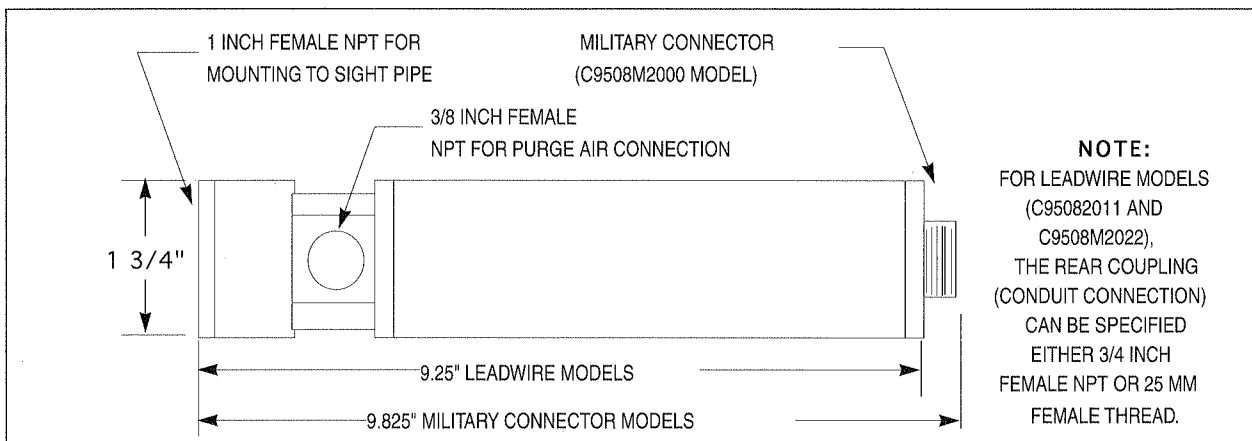

R9008M/R9108M CONTROLLER

SIGNAL INPUTS - One flame sensor input.

OUTPUTS - Relays: Two Form C contacts rated for 3 amperes resistive at 30 VDC, 4 amperes resistive at 250 VAC.

Meter output: 0 to 10 VDC (maximum signal at 10 VDC).

INPUT VOLTAGES - Operates on 120 or 240 VAC (jumper selectable):

120 VAC (102 to 132 VAC, 45 to 65 Hz), factory setting.

240 VAC (204 to 264 VAC, 46 to 65 Hz).

POWER CONSUMPTION - 1.2 VA at 120 or 240 VAC.

TEMPERATURE RANGE-

Operating: -4°F to +185°F (-20°C to +85°C).

Storage: -50°F to +257°F (-46°C to +125°C).

HUMIDITY - 5 to 95% relative (non-condensing).

SHIPPING WEIGHT -

R9008M 3.25 pounds (1.5 kilograms).

R9108M 1.11 pounds (0.5 kilograms)

FAULT RECOGNITION TIME - 12 to 16 seconds.

FLAME RECOGNITION TIME - 1 second maximum.

SELF-CHECKING PERIOD - 4.5 to 6.5 seconds viewing, 0.5 second blocked.

FLAME FAILURE RESPONSE TIME - 1 second or 4 seconds (jumper selectable).

FLAME ON THRESHOLD - Adjustable, 2.5 to 6 volts relative meter reading, measured at TPI inside the controller.

DIMENSIONS -See Figure 4.

MOUNTING -The R9108M is rack mounted (see Form 60-1015, Q9801C Rack Assembly, for details). The R9008M is a panel-mount.

R9108M CONTROLLER MOUNTING

The R9108M Controller is designed to be mounted in the Q9801C Rack. There are two models of the C9801C Rack available:

- Q9801C with 44 pin connections.
- Q9801C with 22 pin connections.
 - Common ground circuit.
 - Common neutral circuit.

If the rack has a locking mechanism, pull the lock tab that releases the lock bar on the card rack.

Insert the controller, make certain that the edge of the circuit board aligns with the guide track. Slide the controller firmly into place (edge connector is keyed between positions 30 and 32) and push the locking tab back in.

FIGURE 4. DIMENSIONS R9108M CONTROLLER AND R9008 CONTROLLER

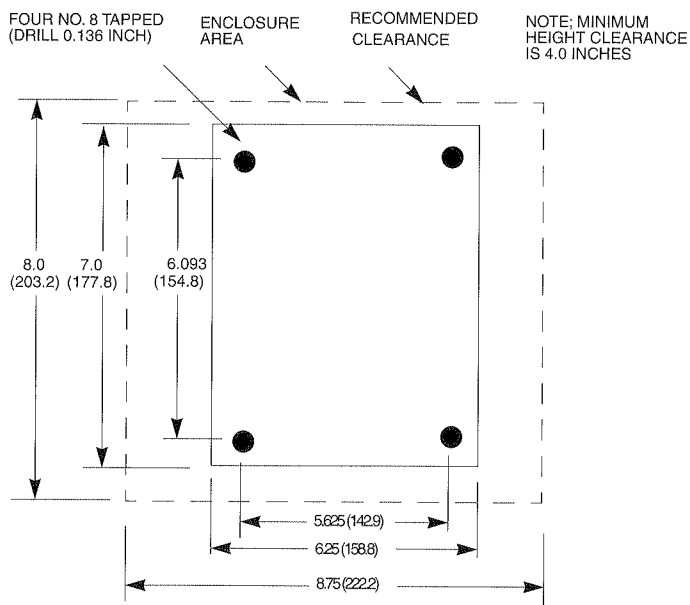

R9008 CONTROLLER
MOUNTING DIMENSIONS IN INCHES
(MILLIMETERS)

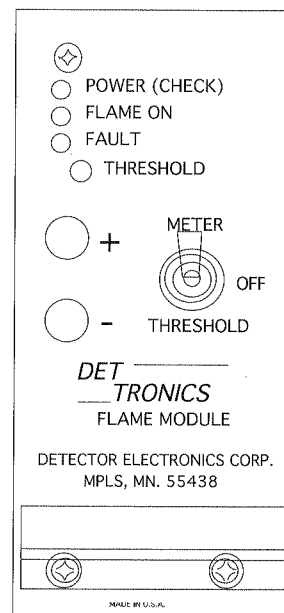

R9108 FRONT PANEL



CAUTION: If The R9108M Controller does not fit, check alignment. Do not force the controller into connectors.



FLAME SCANNER MOUNTING

1. Choose a sighting location where the scanner will have an unobstructed view of the flame under all firing conditions. Greatest ultraviolet radiation is produced near the base of the flame in the area immediately ahead of the burner. A scanner monitoring a pilot flame must sight at a point where pilot and main flames intersect to ensure that a detectable pilot flame will reliably ignite the main flame. For scanner mechanical details see Figure 5.

In multiple burner furnaces, choose a sighting angle with the best possible view of the flame to be monitored and the poorest possible view of other flames in the furnace. The sight pipe should be inclined slightly downward toward the bottom of the furnace so that unburned particles or condensed moisture will not fall or drain into the sensor assembly.

2. Prepare holes in the burner front and windbox to clear the sight pipe at the angle of approach selected. Select a length of 1-inch standard pipe (with NPT thread on one end) no longer than is necessary to place the scanner in an unobstructed and accessible area. (Not to exceed 12").
3. Verify the proper location by viewing through the sight pipe.
4. Thread the scanner assembly onto the 1-inch NPT sight pipe until tight (see to Figure 5).
5. Attach the purge air source to the 3/8-inch NPT purge air inlet. The purge air supply must be oil-free and dry. The air pressure should be slightly greater than furnace pressure to keep debris out of the sight pipe and away from the focal lens. Special precautions should be taken in pressurized furnace applications. Consult the factory for further assistance.
6. Tack weld the sight pipe to the burner front at the selected location and angle. Due to heat expansion, it is recommended that the sight pipe not be fixed at the burner wall.
7. In many instances it is convenient to attach the sight pipe to a swivel mount (see "Accessories") that, in turn, is attached to the sight pipe mounting surface. This mount allows angular adjustment within a cone of approximately 40 degrees.
8. Electrical connections are made at the opposite end of the scanner housing. The C950M Scanner is available with a military connector, 3/4-inch NPT connector, or 25mm connector. (Available connector and cable assemblies for connecting the scanner to the controller are listed in the "Accessories" section.) It is recommended that 0.5 inch flexible metal conduit be used. Terminate the electrical connections at a junction box and splice the leadwires to conductors extending to the controller. For a watertight connection, use an appropriate fitting and a liquid-tight conduit arranged to angle downward from the scanner. The maximum distance (in cable feet) between controller and scanner is 500 feet. For wiring runs that exceed 100 feet, the use of shielded cable is recommended.



FIGURE 5.

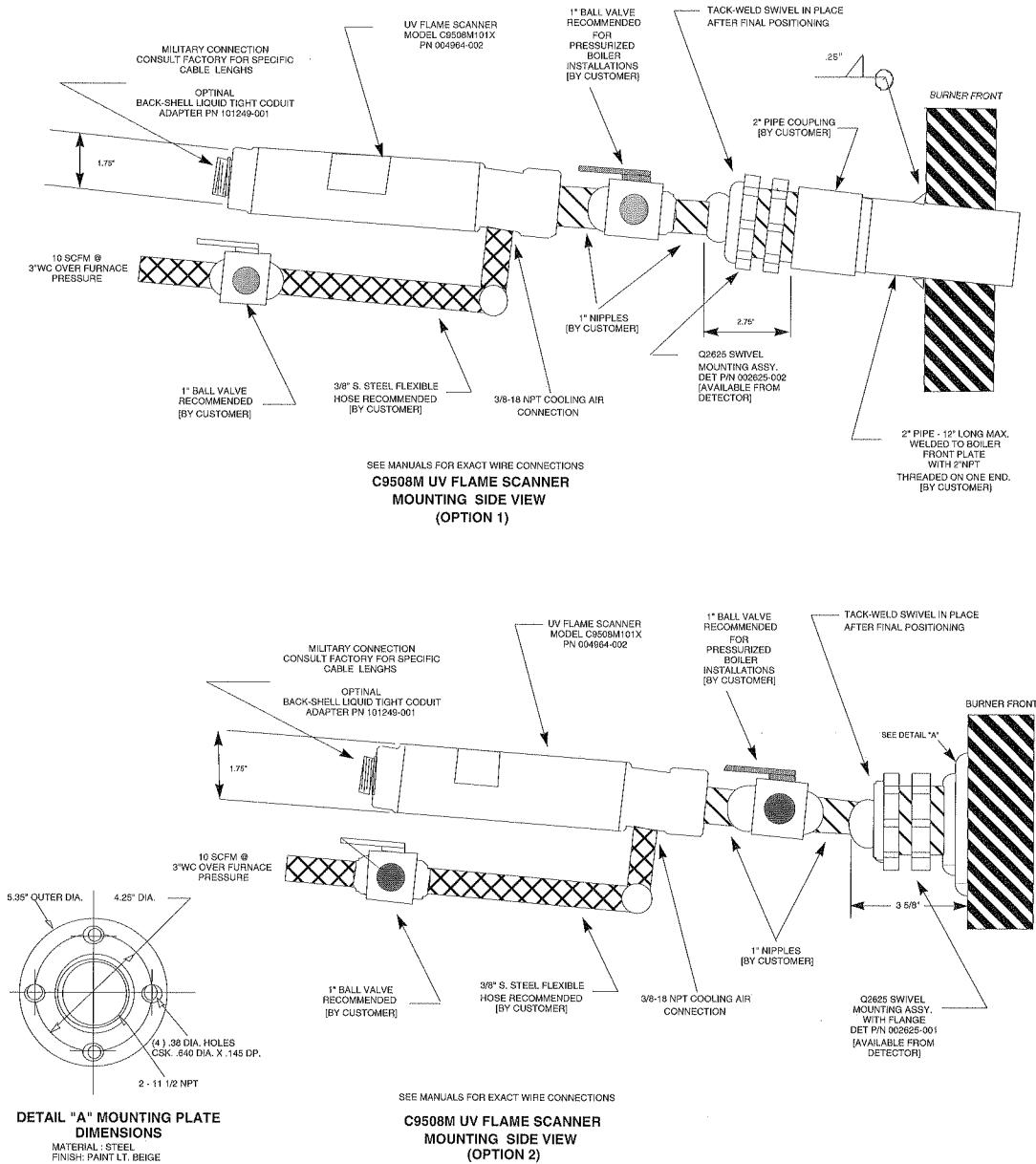

CONTROLLER WIRING

1. The electrical connections for the R9008M Controller are shown in Figure 6, Figure 7 for the R9108M Controller.
2. The R9108M Controller is inserted in a card edge connector with attached screw terminals (located on rear of rack), which are designed for a maximum of two 18 AWG lead-wires Controller terminal numbers are marked on the backplane circuit board (do not use terminal block numbers).

Wire in accordance with the National Electrical Code and local code requirements.

FIGURE 6. INPUT VOLTAGE JUMPER SETTINGS

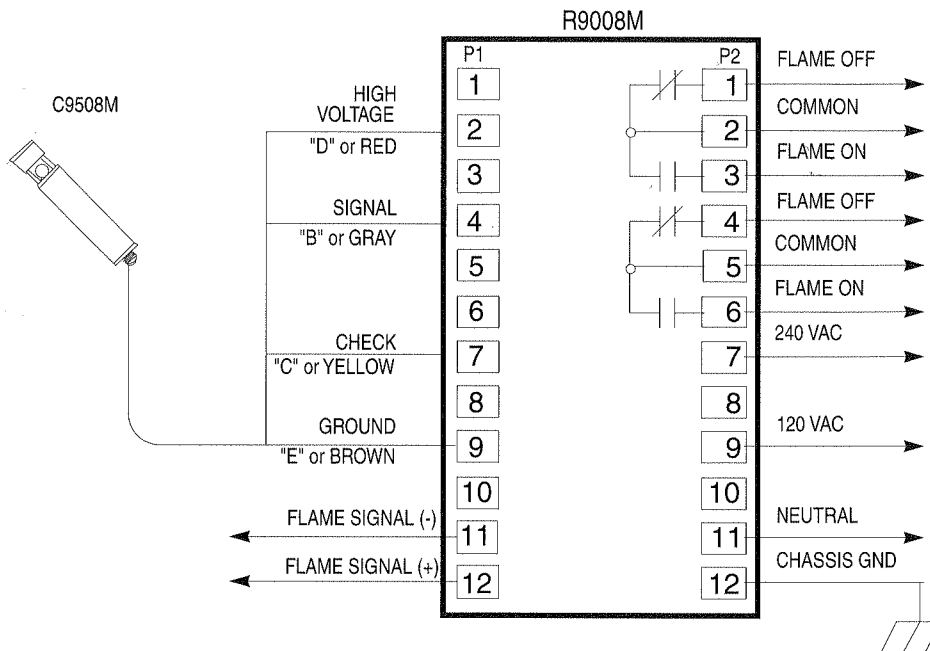

Scanner Leadwires	Connector Pins	Cable Wires	Cable Wires
	A (not used)	Orange (not used)	Orange (not used)
Gray	B	Blue	Green
Yellow	C	Yellow	White
Red	D	Red	Red
Brown	E	Black	Black

Both the R9108M and the R9008M Controllers operate on 120 VAC or 240 VAC. However, the installer must ensure that the power source is connected to the correct input terminals and that the voltage selection jumpers are correctly installed.

R9108M Controller (Reference Figures 7 and 9):

For 120 VAC operation (Factory Setting): Connect AC source to 9 (Hot) and 5 (Neutral) on the Q9801C Rack. Ensure that Jumpers W8, W6 and W4 are installed. **For 240 VAC operation:** Connect AC source to 9 (Hot) and 5 (Neutral) on the Q9801C Rack. Ensure that Jumpers W7, W5 and W3 are installed.

R9008M Controller (Reference Figures 6 and 8):

For 120 VAC operation (Factory Setting): Connect AC source to P2 9 (Hot) and P2 11 (Neutral). Ensure that Jumpers W8, W6 and W4 are installed. **For 240 VAC operation:** Connect AC source to P2 7 (Hot) and P2 11 (Neutral). Ensure that Jumpers W7, W5 and W3 are installed.

FIGURE 7. R9108 CONTROLLER WIRING

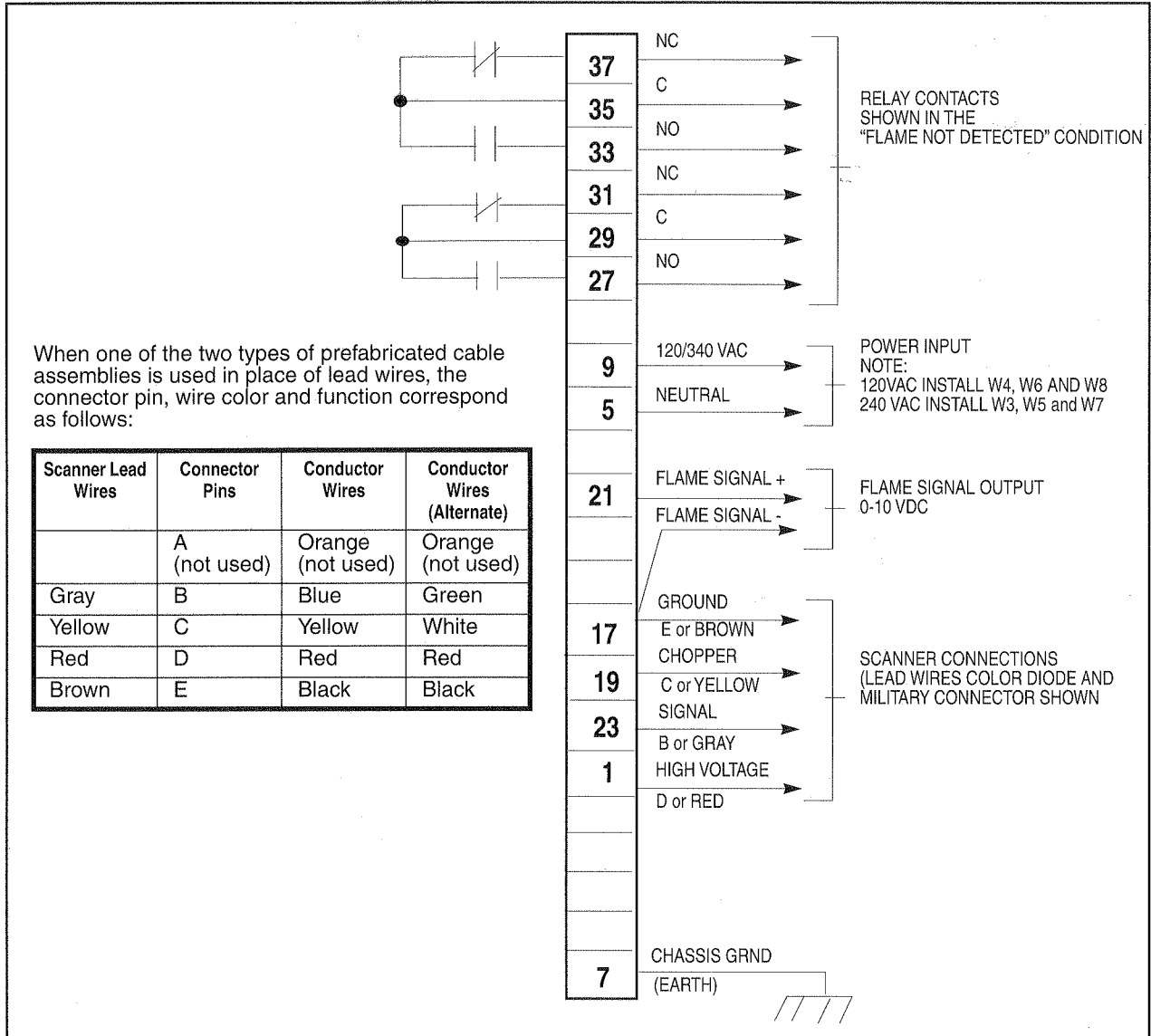

FLAME OFF JUMPER SETTINGS

Both the R9108M and R9008M Controllers can be set for a 1 second or a 4 second flame off delay. The flame off delay is usually referred to as the flame failure response time (FFRT).

For 1 second delay: Ensure that Jumper W2 is installed and Jumper W1 is not installed.

Reference Figure 8 for R9008M and Figure 9 for R9108M Controllers.

For 4 second delay:

Ensure that Jumper W1 is installed and Jumper W2 is not installed.

Reference Figure 8 for R9008M and Figure 9 for R9108M Controllers.

FIGURE 8.

Flame Off delay set for 1 second with W1 installed

Flame Signal Jacks

Flame On (Red LED)

Power (Check) - Green LED

Scanner Fault - Amber LED

Flame Off delay set for 4 seconds with W2 installed.

Gain Select Switch
Rocker 1 closed = lowest gain setting.
Rocker 6 closed = highest gain setting.

120VAC setting

P1

TPI
Threshold
Voltage test point.

240 VAC setting

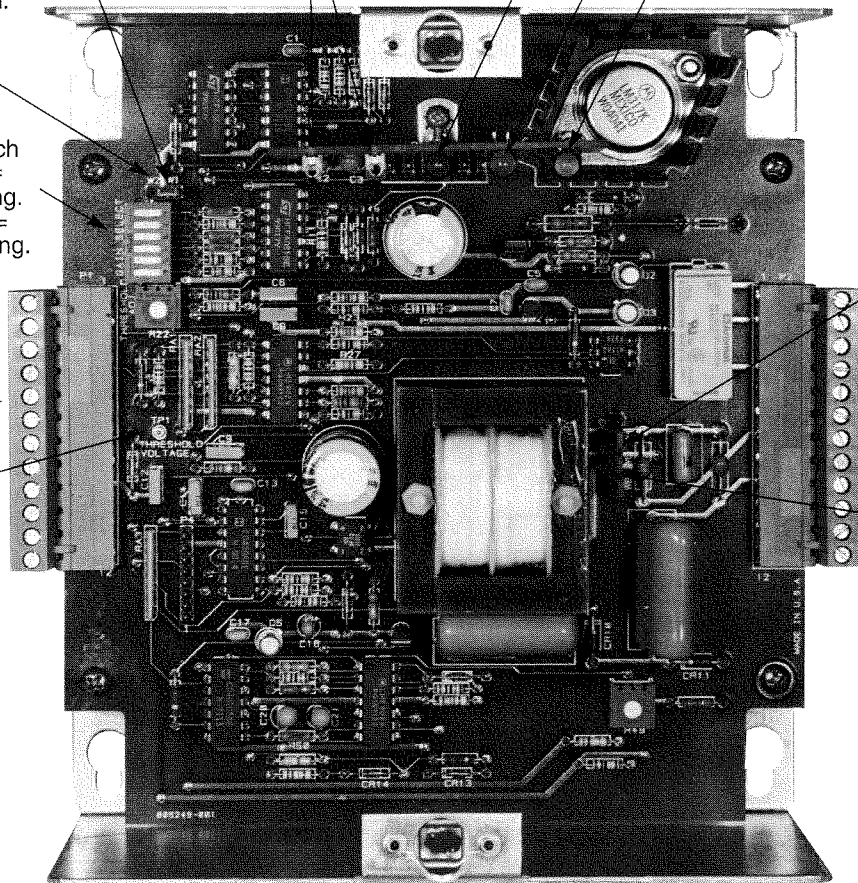

SIGNAL ADJUSTMENT

1. Ignite the flame(s) to be monitored following the normal burner light-off procedure.
2. The Gain Select Switches and flame threshold potentiometer are located on the circuit board of both the R9108M and R9008M Controllers. These adjustments are accessible only when the controller cover is removed for the R9008M, and when the R9108M is removed from the rack.
3. To adjust the flame signal:
 - a. Remove the cover for the R9008M; pull out the R9108M from the rack.
 - b. Adjust the flame threshold potentiometer to minimum (fully counterclockwise).
 - c. Close Gain Select Switch position 1 and make sure that all other positions are open. This is the lowest gain setting.
 - d. Monitor the flame signal output from the jacks on the face-plate of the controller.
 - e. Observe the meter reading. For reliable operation, a signal reading should exceed the Flame On threshold by 4 volts. If it does not, increase gain by closing Gain Select Switch 2 and opening Gain Select Switch 1. If more gain is required, close Gain Select Switch 3 and open Gain Select Switch 2. Continue until a 7-8 volt signal is obtained.
 - f. An inadequate signal is usually the result of improper sighting. Vary the angle of the sight pipe to achieve the highest signal voltage reading.

- g. If the scanner is used to monitor both pilot and main flames, adequate flame signal from each should be verified with the other flame shut off. If a good signal can be acquired from both flames only at two different sighting angles, either the sight pipe should be relocated to a more appropriate sighting area or the use of two scanner/controllers should be considered.
- h. In multiple burner furnaces where individual flame discrimination is required, it is possible that a strong signal may be received from an interfering flame as well as from the flame of interest. The best way to correct this condition is to restrict the size of the viewing orifice on the scanner so that the signal intensity from both flames is reduced. Assuming that the monitored flame, which has an optimized sighting angle, will provide a greater signal than an adjacent flame, a reduction of signal strength (by reducing incident light radiation) will permit the differences in signal level from the two flames to be recognized. The unwanted signal can then be "tuned out" by adjusting the Gain Select Switches and increasing the Flame-On threshold (see "Threshold Adjustment").

Satisfactory operation can be obtained with an attenuate signal reading as low as 4 volts.

4. IMPORTANT: The high tension electric spark used to ignite a pilot name is an emitter of ultraviolet radiation.

To ensure that the sighting arrangement does not permit the detection of direct or reflected spark energy, it should be determined that a flame signal reading of no more than 1 volt is obtained with fuel sources shut off and spark energized. Re-align or optically shield the igniter, if necessary, to avoid spark detection.

5. IMPORTANT: A sensor responsive to a pilot flame is not properly applied if it detects a name that is too small to reliably ignite the main burner.

This can be checked by reducing the pilot flame size to the smallest that can be detected (Gain Select set to maximum - Switch 6 closed) and then determining that such reduced flame will readily ignite the main burner.



CAUTION If ignition of the main name does not occur at once, or is slower than usual, shut off fuel immediately, readjust the sensor to sight further out, and repeat the test.

- 6. IMPORTANT: When satisfactory sighting has been achieved, the sight pipe should be permanently welded in place at the burner front to maintain the selected position. If a swivel mount is used, tack weld it to prevent further movement.
- 7. After proper signal adjustment has been determined, flame failure response should be checked by closing manual fuel shutoff valves during burner operation. Shutdown and alarm should occur not more than 4 seconds after the flame goes out for a flame off jumper setting of 4 seconds, or not more than 1 second after the flame goes out for a flame off jumper setting of 1 second.

THRESHOLD ADJUSTMENT

R9008M Controller - Once the background radiation detected is below 3.5 volts, remove the controller cover, then connect meter (-) to the flame signal test jack (black) and meter (+) to TPI. Observe the meter reading. This is the Flame On Relay threshold setpoint. Adjust the potentiometer on the R9108M to obtain a reading that is 2 volts higher than the background radiation observed in the previous step.

R9108M Controller - Once the background radiation detected is below 3.5 volts, connect the meter leads to (+) and (-) on the front panel of the controller. Flip the front panel switch to the threshold position and maintain it there. Observe the reading. This is the Flame On Relay threshold setpoint. Adjust the potentiometer on the R9108M to obtain a reading that is 2 volts higher than the background radiation observed in the previous step.

TROUBLESHOOTING

Extra tube modules (a minimum of 1 and approximately 1 spare of every 10 installed) and an extra controller should be kept on hand in order to make trouble shooting easier and to minimize downtime. Refer to Figure 10 for part identification.

FIGURE 9. C9508M SCANNER PARTS IDENTIFICATION

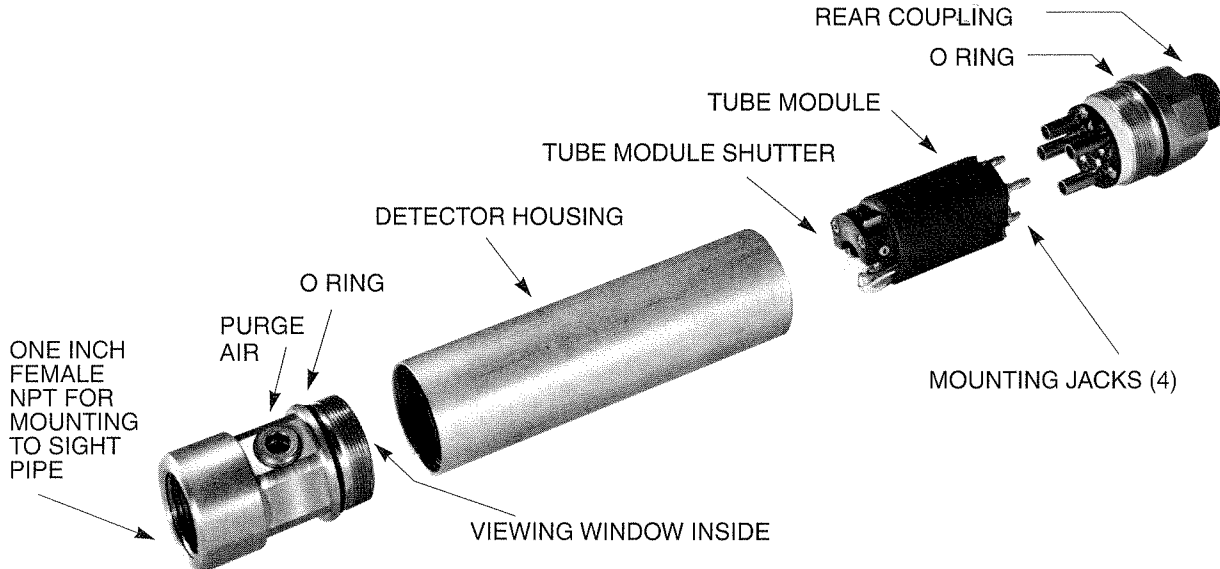

Problem: Flame On Relay drops out or fails to energize with flame present.

1. Check the Controller:
 - Make sure that the supply voltage is present and that the Power LED is lit and goes off for approximately 0.5 seconds every 5 to 7 seconds. If the supply voltage is present but the power LED) is not lit or is not pulsing off, replace the Controller. Otherwise, proceed with troubleshooting.
 - Using a voltmeter set for DC volts, measure the voltage across terminal P1-19 (+) and P1-17 (-) for a check pulse output. This pulsing signal should measure approximately 26 VDC and last approximately 0.5 seconds with the measurement dropping to 0 VDC for 5 to 7 seconds between pulses. If this signal is not present or is not as described, replace the R9108M Controller. Otherwise, proceed with troubleshooting.
 - Measure the voltage across terminals P1-1 (+) and P1-23 (-) for the W tube supply voltage. This should measure +290 VDC +20 VDC. Adjust R17 on the controller if necessary. If this voltage is not present or cannot be adjusted to the correct voltage, replace the R9108M Controller. Otherwise, proceed with troubleshooting. Do NOT exceed 290 VDC.
 2. If the Controller is operating correctly as described above, confirm the following operation of the Scanner.
 - Ensure that the scanner sight pipe is clear of obstructions and that the scanner has a clear view to the base of the burner flame.
 - Ensure that the scanner lens is clean.
- If either a or b above is the problem, ensure that sufficient cooling/purge air is supplied to the scanner to keep the sighting arrangement clear. Readjust the scanner sighting angle if necessary.
3. If either of the above is not the problem, remove the scanner tube module housing and check the tube module operation.



CAUTION Tube module plug-in jacks contain high voltage. Remove power to module by disconnecting power to the controller or removing the military connector at the scanner prior to removing the housing.

- Visually check the tube module shutter operation. With power reapplied to the controller and the military connector attached, the shutter should cover the tube sighting orifice every 5 to 7 seconds for approximately 0.5 seconds. If the shutter fails to return to the viewing position, replace the tube module.
- Check the tube response to a flame or other W source. Expose the tube to W radiation from a W flashlight or a good flame source. The Flame On LED at the controller should come on. If there is no response, replace the tube module.

If the controller does respond with Flame On LED, check the output at the Flame Signal meter jacks on the faceplate of the controller. If signal level is less than 6 VDC, the UV tube may be weak or the controller gain switches may need to be adjusted. Confirm that the controller gain is set correctly or replace the tube module.

Problem: Fault LED is lit.

1. The self check circuit has detected a malfunction in the system.
 - With no flame present at the scanner, the Flame On LED is lit This indicates a UV tube malfunction. Replace the tube module.
 - With the flame present at the scanner, the Power (Check) LED is operating normally (0.5 sec on, 5 to 7 seconds off). This indicates a wiring problem or a scanner shutter malfunction.

Check the scanner wiring. Remove the wires from P1-19 and P1-17. The loop resistance should measure 1200 ohms + 10%. If the loop resistance is normal, the shutter has malfunctioned and the tube module must be replaced.

Problem: Operation is normal (with name present, name relay is energized) but FAULT LED is on.

This indicates that the tube module shutter is stuck open or otherwise malfunctioning. The tube module shutter should momentarily close every 5 to 7 seconds with power applied to the system. Visually check the tube module shutter operation. If the shutter is not operating correctly, replace the tube module.



CAUTION: Operation at excessive temperature may lead to tube module malfunction. If the temperature sticker on tube module is black the temperature rating has been exceeded.

TUBE MODULE REPLACEMENT

Refer to Figure 1

1. Remove power from the system.
2. Unscrew the coupling at the rear of the scanner (for scanners with a military connector, it may be easiest to first disconnect that connector, then remove the rear coupling).
3. The tube module has four mounting jacks that plug into the side of the rear coupling. To remove the tube module, simply pull straight away from the rear coupling.
4. To replace the tube module, line up the mounting jacks on the tube module with the connectors on the coupling and press firmly into place.
5. Reassemble the detector assembly.



ORDERING INFORMATION

Mounting Rack Q9801C plus Blank Panels DE3420-01 through 04.

When ordering specify:

- R9008 Controller (Panel Mount)
- R9108M Controller (Rack Mount)
- C9508M2000 Scanner. Equipped with military connector - requires prefabricated scanner cable assembly, (see list below).
- C9508M2011 Scanner: Equipped with 3/4-inch NPT internal threaded connector with 10 foot lead-wires.
- C9508M2022 Scanner: Equipped with 25 millimeter internal threaded connector with 10 foot lead-wires.
- DE5213A Replacement Tube Module

ACCESSORIES

DE601-006A - 5 pin military connector kit for use with customer supplied Hypalon cable.

Q2625A1314 Swivel Mount for angular adjustment of the sight pipe.

Q2625A1303 Swivel Assembly with mounting plate.

W8066 Portable W Test Lamp

Prefabricated Scanner Cables

DE4599-010 Military/Flex Conduit Connector with 10 feet of Hypalon Cable

DE4599-020 Military/Flex Conduit Connector with 20 feet of Hypalon Cable

DE4599-040 Military/Flex Conduit Connector with 40 feet of Hypalon Cable

DE4599-060 Military/Flex Conduit Connector with 60 feet of Hypalon Cable

DE4599-080 Military/Flex Conduit Connector with 80 feet of Hypalon Cable

DE4599-100 Military/Flex Conduit Connector with 100 feet of Hypalon Cable

DE4360-010 Connector with 10 feet of Cable

DE4360-020 Connector with 20 feet of Cable

DE4360-040 Connector with 40 feet of Cable

DE4360-060 Connector with 60 feet of Cable

DE4360-080 Connector with 80 feet of Cable

DE4360-100 Connector with 100 feet of Cable



NOTICE

When Fireeye products are combined with equipment manufactured by others and/or integrated into systems designed or manufactured by others, the Fireeye warranty, as stated in its General Terms and Conditions of Sale, pertains only to the Fireeye products and not to any other equipment or to the combined system or its overall performance.

WARRANTIES

FIREYE guarantees for one year from the date of manufacture of its products to replace, or, at its option, to repair any product or part thereof (except lamps, electronic tubes and photocells) which is found defective in material or workmanship or which otherwise fails to conform to the description of the product on the face of its sales order. **THE FOREGOING IS IN LIEU OF ALL OTHER WARRANTIES AND FIREYE MAKES NO WARRANTY OF MERCHANTABILITY OR ANY OTHER WARRANTY, EXPRESS OR IMPLIED.** Except as specifically stated in these general terms and conditions of sale, remedies with respect to any product or part number manufactured or sold by Fireeye shall be limited exclusively to the right to replacement or repair as above provided. In no event shall Fireeye be liable for consequential or special damages of any nature which may arise in connection with such product or part.



® FIREYE®
3 Manchester Road
Derry, New Hampshire 03038

65-8060
AUGUST 1994
