



Fireye[®] Nexus Modbus Interface NXMBI

DESCRIPTION

The NXMBI Modbus interface is designed to connect Fireye's range of Nexus Controllers to other devices using the 'Modbus' protocol, using either 2 wire or 4 wire RS485 / RS422.

The actual protocol is MODBUS RTU. There is also a MODBUS ASCII protocol that is not supported.

The hardware device used is a KD485-PROG, which is programmed by Fireye to perform the Modbus protocol conversion. This device is designed to fit a standard DIN rail (35mm, symmetric rails).

A network of up to 15 Fireye Nexus devices can be linked to modbus with just one modbus interface.

Consideration needs to be given to the total number of registers to be communicated, refer to page 5 for further details.

CONNECTIONS

The KD485 has two 'ports', i.e. communications channels.

Port 1 is used to connect to the Fireye equipment, and can be found on the 8-way connector on the bottom of the unit (as it would normally be mounted). This connector is also used to supply power to the unit.

Adjacent to Port 1 is a telephone style RJ11 / CAT6 socket. **This should not be used.**

Port 2 is used to connect to modbus, and can be found on the top of the unit, as it would normally be mounted.

Adjacent to Port 2 are four dipswitches which are factory set to **SW1 = ON, SW2 = ON, SW3 = OFF, SW4 = OFF**. For the converter to work reliably, these switches must be left in these positions.

All signal cables (and ideally the power input) should be wired with braided screened cable. The screens should be connected to EARTH (not 0v) on at least one end. Where cable screen clamps are provided they must be used as described for that product. If a screening clamp is not provided, the braid should be connected directly to an earthing point and made as short as possible.

FIGURE 1.

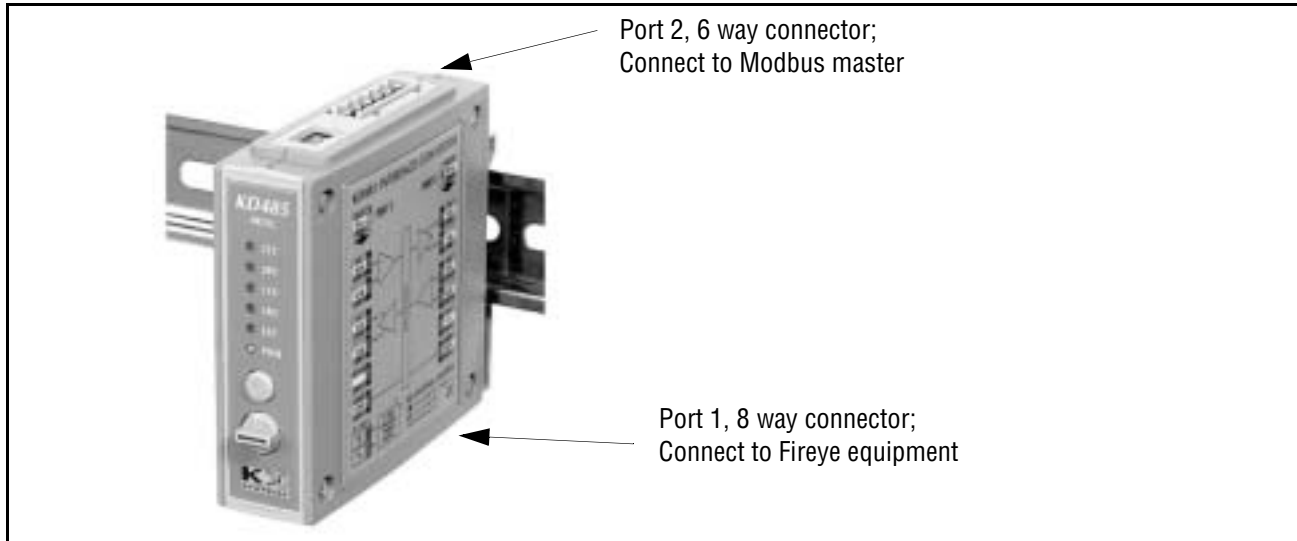

FIGURE 2. Connection to MODBUS with 2 wire RS485

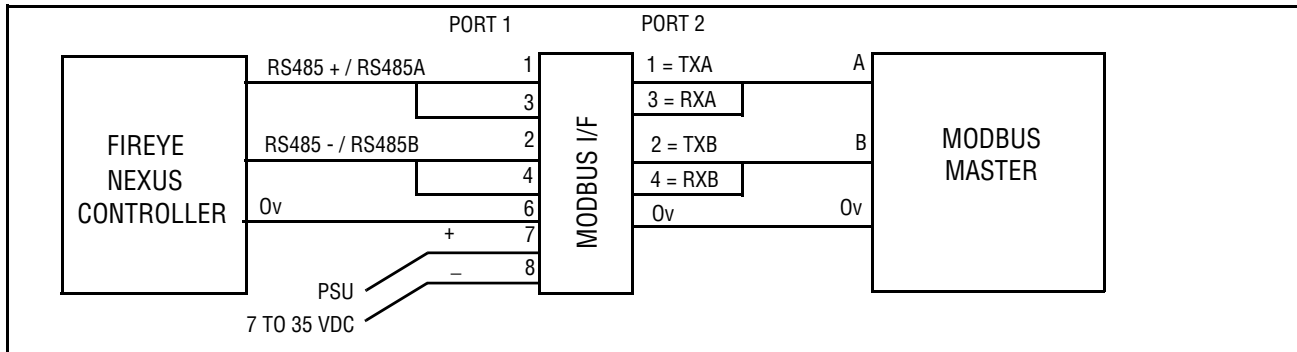
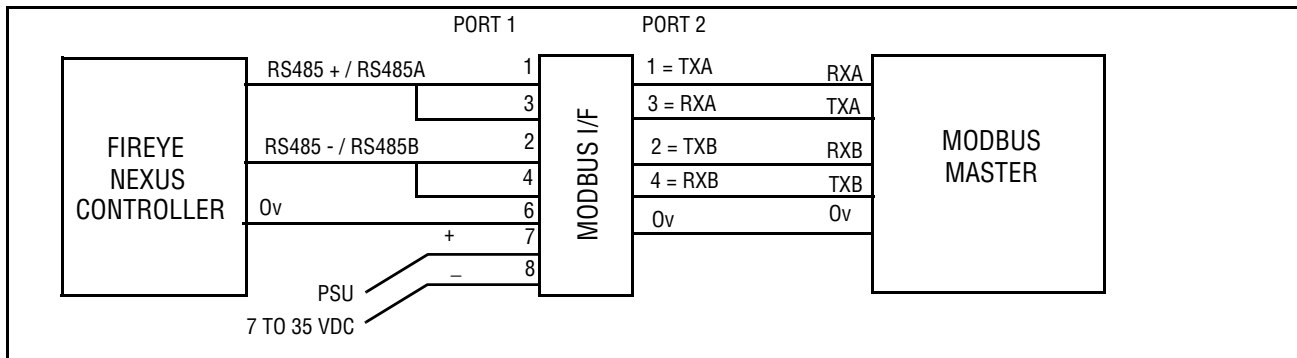

FIGURE 3. Connection to MODBUS with 4-wire RS485



NEXUS EQUIPMENT	NXMBI CONNECTIONS	
	PORT 2 (1, 3)	PORT 1 (2, 4)
NX-3100 / 4100	PD11	PD12
PPC5000	PB1	PB2



SETTINGS

The port 1 settings (the Fireeye protocol) are not adjustable as all Fireeye Nexus equipment is 9600 baud, 8 bits, no parity, 1 stop bit. This unit will automatically select its unit address on the Fireeye Nexus bus. If at any point it sees another item on the bus with the same unit address, it will choose another unused address.

The port 2 settings (Modbus) can be changed using the push button and rotary switch on the front of the unit. At the factory, these default settings are entered:

- Baud rate = 9600
- Settings = 8 bits, no parity, one stop bit.
- Modbus address = 100

Changing the settings can be done at any time and is accomplished by entering an access code, then the actual settings using the rotary switch. It should be possible to adjust all the settings in under a minute.

The following table shows what to enter for each setting. The best way to detail the procedure is by example.

Example 1: Set the Modbus baud rate to 9600 (Access code 151).

1. Set the rotary switch to the first digit of the access code. This is always one (1).
2. Push the green button.
3. Set the rotary switch to the second digit of the access code. This is five (5) for this example.
4. Push the green button.
5. Set the rotary switch to the third digit of the access code. This is always one (1).
6. Push the green button. The red EXE light should now come on, indicating that the access code has been accepted.
7. Set the rotary switch to the code given for the desired baud rate. In this example, 9600 is 'B'.
8. Push the green button. The red EXE light will go off, and the baud rate has now been set.

Example 2: Set the Modbus slave address to 29 (Access code 161).

1. Set the rotary switch to the first digit of the access code. This is always one (1).
2. Push the green button.
3. Set the rotary switch to the second digit of the access code. This is six (6) for this example.
4. Push the green button.
5. Set the rotary switch to the third digit of the access code. This is always one (1).
6. Push the green button. The red EXE light should now come on, indicating that the access code has been accepted.
7. Set the rotary switch to the number of hundreds for the address. In this case, it is zero (0) since the address is 029.
8. Push the green button.
9. Set the rotary switch to the number of tens for the address. In this case, it is two (2) since the address is 029.
10. Push the green button.
11. Set the rotary switch to the number of units for the address. In this case, it is nine (9) since the address is 029.
12. Push the green button. The red EXE light will go off, and the slave address has now been set.

FUNCTION	ACCESS CODE	DATA 1	DATA 2	DATA 3
MODBUS BAUD RATE	151	0 = 110 1 = 134.5 2 = 150 3 = 300 4 = 600 5 = 1200 6 = 2000 7 = 2400 8 = 3600 9 = 4800 A = 7200 B = 9600 C = 19200 D = 38400 E = 57600 F = 115200		
MODBUS SLAVE ADDRESS (1 TO 247)	161	HUNDREDS (0 TO 2)	TENS (0 TO 9)	UNITS (0 TO 9)
MODBUS COMMS SETTINGS (BITS, PARITY, STOP BITS)	171	0 = 8, N, 1 1 = 8, N, 2 2 = 7, N, 1 3 = 7, N, 2 4 = 8, E, 1 5 = 8, E, 2 6 = 7, E, 1 7 = 7, E, 2 8 = 8, O, 1 9 = 8, O, 2 A = 7, O, 1 B = 7, O, 2		

Notes:

- If an incorrect access code is entered, the access code system will reset allowing another try.
- If at any time during the procedure the green button is not pushed for sixty seconds, the access code system will reset. This is useful if you ‘forget where you are’ at any time.
- Slave addresses must be in the range 1 – 247. Values outside this range will be ignored (the access code system will reset).
- Setting the comms settings (access code 171) to values outside the range will be ignored (the access code system will reset).

All settings are stored in EEPROM, which means that they are remembered after a power down.

If you want to check the settings, the easiest way is to use ComFire software running on a PC connected to the Fireye Nexus bus side of the converter – port 1. A suitable RS232 / RS485 converter will be needed unless the PC has a built in RS485 port.

On start-up of the program, or when the ‘scan’ button is pushed, the ‘about’ window will open and show a list of all units connected. The NXMBI Modbus interface should be as shown.



The interface will show as a NXMBI, followed by its firmware version – in this case v0.10.

The Modbus address is shown next – here it is 69, followed by the Modbus baud rate, number of bits, parity and stop bits.

MODBUS REGISTERS

The NXMBI Modbus interface supports the following Modbus registers:

- **COILS** (1 to 320). These registers can be written to by a Modbus master to provide control of Fireye Nexus units.
- **INPUT REGISTERS** (1 to 4000, 16 bit). These can be read by a Modbus master monitor combustion and other variables from the Fireye Nexus units.
- **HOLDING REGISTERS** (1 to 1600, 16 bit). These can be written to by a Modbus master to provide control of Fireye Nexus units.

It is strongly recommended that only the registers that are actually of interest for the end user / current application are read.

Block-reads and block-writes have been allowed, but these should be used with care. It is a very bad idea to simply do a block read of say 50 registers from unit 1. It is never going to be the case that more than five or six consecutive registers actually have meaningful data in them for any one application. If you do a block read including registers without important data in them, you will be slowing the update times for the useful registers.

The NXMBI interface 'remembers' which registers have been accessed and will update them continuously in the background - invisible to the modbus master system. The modbus master can read or write to registers as often as it likes, but how recent the data is that it reads back depends on how many registers have been requested since power was applied to the NXMBI unit (or it was re-booted - see coil write #20).

Typically the NXMBI unit will refresh two of its registers per second. There is a recommended maximum of 100 registers that can be refreshed, so the worst-case refresh time would be 50 seconds.

NOTE - THIS IS TRANSPARENT TO THE MODBUS MASTER, WHICH CAN READ/WRITE TO THE NXMBI AS OFTEN AS IT LIKES.

The NXMBI will return a modbus error if more than 200 items are requested.

As long as only the registers with meaningful information are requested, the refresh times will be much faster (typically a few seconds). This is why block reads must be used only with care.

Some modbus applications refer to 'register numbers' and some refer to 'register addresses'. The tables below all give a 'register number'. Where the application requires a 'register address' you must subtract 1. For example register number 201 can be accessed by register address 200.

Where a formula is given for the register number, 'unit' refers to the unit address of a device on the Fireye bus. Any multiplications in the formula must be done before any additions.



COILS – WRITE TO (MODBUS FUNCTION CODES 5 & 15)

There are 320 coil write registers available in the NXMBI Modbus interface. Coils 1 to 20 relate to the device at address zero on the Fireye Nexus bus, coils 21-40 relate to the device at unit address one on the Fireye Nexus bus and so on.

Once a coil is written to, this value will be transmitted to the appropriate Fireye Nexus unit indefinitely, until either the value of the coil register is changed again, or the power is removed from the NXMBI interface.

Note: Not all items are valid for all types of equipment.

REGISTER	FUNCTION	DETAILS
1 + (unit x 20)	Setpoint Select	0 = Run to setpoint 1 1 = Run to setpoint 2 (use for night setback etc.)
2 + (unit x 20)	Release to Ignite	If used, must be 1 to allow the burner to ignite.
3 + (unit x 20)	Release to modulate	If used, must be 1 to allow the burner to modulate from low fire after light-up.
4 + (unit x 20)	Lead boiler Select	Choose this to be the lead boiler if boiler sequencing is in operation.
5 + (unit x 20)	Fault Mute	Due to differing approvals requirements, this function may be disabled.
6 + (unit x 20)	Oxygen Trim	1 = Turn trim ON
7 + (unit x 20)	Boiler Sequencing Enable	1 = Enable boiler sequencing (lead/lag). Must be done for every unit.
8 + (unit x 20)	Burner ON/OFF	If the burner is firing / able to fire, it can be turned off by writing a zero to this register.
9 + (unit x 20)	Reset Hours Run & Averages	Set to 1 to clear data. This should be set back to zero to allow the counters to work again.
10 + (unit x 20)	Profile Select	Allow the firing of a different fuel / air ratio for the same fuel combination. Integrated burner control models only.
11 + (unit x 20)	Forced Lockout	Will cause the unit concerned to generate a lockout type fault. Integrated burner control models only.
12 + (unit x 20)	Reserved for future use.	Note: When a '1' is written to coil 20 (at address 19), the modbus interface will be re-booted. This only happens when the register value was 0 and is changed to 1 and will clear the list of items that will be updated.



INPUT REGISTERS – READ FROM (MODBUS FUNCTION CODE 4)

There are 4000 input registers available in the NXMBI Modbus interface.

These are all 16 bit registers holding integer numbers. When a number has decimal information, it is multiplied up to give an integer number.

For example:

173 °C Flue Temperature will read as 173

3.2% oxygen will read as 32.

17.4° servo position will read as 174.

5.0 bar setpoint will read as 50.

5.00 bar setpoint will read as 500.

While the decimal precision is different for different items, it will not change for any particular item during normal use.

Registers 1 to 200 relate to the device at address zero on the Fireye Nexus bus, and access information from its 'engineer's key'.

Registers 201 to 250 relate to the device at unit address zero on the Fireye Nexus bus and access data from its 'display values'.

Registers 251 to 450 relate to the device at unit address 1, and access data from its 'engineer's key'

Registers 451 to 500 relate to the device at unit address 1 on the Fireye Nexus bus and access data from its 'display values'.....and so on.

The first time one of these registers is read, the value returned will be zero. The first valid data will appear a few seconds later and all future reads will be up to date – whatever the elapsed time between them.

Note: Not all items are valid for all types of equipment.

REGISTER	FUNCTION	DETAILS
1 + (unit x 250)	Engineer's Key 1	Device specific data.
2 + (unit x 250)	Engineer's Key 2	Device specific data.
... ..		
199 + (unit x 250)	Engineer's Key 199	Device specific data.
200 + (unit x 250)	Engineer's Key 200	Device specific data.
201 + (unit x 250)	Fuel 1 Drive Position	As on product display.
202 + (+ unit x 250)	Fuel 2 Drive Position	As on product display.
203 + (+ unit x 250)	Fuel 3 Drive Position	As on product display.
204 + (+ unit x 250)	Option 1 Drive Position	As on product display.
205 + (+ unit x 250)	Option 2 Drive Position	As on product display.
206 + (+ unit x 250)	Option 3 Drive Position	As on product display.
207 + (unit x 250)	Air Damper 1 Drive Position	As on product display.
208 + (+ unit x 250)	Air Damper 2 Drive Position	As on product display.
209 + (unit x 250)	Air Damper 3 Drive Position	As on product display.
210 + (+ unit x 250)	Air Damper 4 Drive Position	As on product display.
211 + (+ unit x 250)	Option 4 Drive Position	As on product display.

REGISTER	FUNCTION	DETAILS
212 + (+ unit x250)	Option 5 Drive Position	As on product display.
213 + (+ unit x250)	Measured Value	As on product display.
214 + (unit x 250)	Efficiency	As on product display.
215 + (unit x 250)	Inlet Temp	As on product display.
216 + (unit x 250)	O2 Level	As on product display.
217 + (unit x 250)	CO2 Level	As on product display.
218 + (unit x 250)	CO Level	As on product display.
219 + (unit x 250)	Hours Run	As on product display.
220 + (unit x 250)	Burner Status	As on product display.
221 + (unit x 250)	Trim	As on product display.
222 + (unit x 250)	Setpoint	As on product display.
223 + (unit x 250)	Flue Temp	As on product display.
224 + (unit x 250)	Fault Number	As on product display.
225 + (unit x 250)	Smoke Level	As on product display.
226 + (unit x 250)	SOx Level	As on product display.
227 + (unit x 250)	NOx Level	As on product display.
228 + (unit x 250)	Fuel	As on product display.
229 + (unit x 250)	Profile Set	Do not use.
230 + (unit x 250)	Option Set	Do not use.
231 + (unit x 250)	Modulation Rate	As on product display.
232 + (unit x 250)	Fuel Flow Rate	As on product display.
233 + (unit x 250)	Averaged Efficiency	As on product display.
234 + (unit x 250)	Averaged Modulation	As on product display.
235 + (unit x 250)	Total Fuel Flow	As on product display.
236 + (unit x 250)	Gas Pressure	As on product display.
237 + (unit x 250)	Valve Prove Status	As on product display.
238 + (unit x 250)	Flame Signal	As on product display.
239 to 250 + (unit x 250)	Reserved for future use	

HOLDING REGISTERS – WRITE TO (MODBUS FUNCTION CODES 6 & 16)

There are 1600 holding (write) registers available in the NXMBI Modbus interface. These are 16 bit registers holding integer values.

Registers 1 to 100 relate to the device at address zero on the Fireye Nexus bus, coils 101-200 relate to the device at unit address one on the Fireye Nexus bus and so on.

Once a holding register is written to, this value will be transmitted to the appropriate Fireye Nexus unit indefinitely, until either the value of the coil register is changed again, or the power is removed from the NXMBI interface.

Note: Not all items are valid for all types of equipment.



REGISTER	FUNCTION	DETAILS
1 + (unit x 100)	Setpoint 1 Control Value	Strip decimal information – i.e. 999 = 99.9 = 9.99
2 + (unit x 100)	Setpoint 2 Control Value	Strip decimal information – i.e. 999 = 99.9 = 9.99
3 + (unit x 100)	Setpoint 1 Low Control Limit	Strip decimal information – i.e. 999 = 99.9 = 9.99
4 + (unit x 100)	Setpoint 2 Low Control Limit	Strip decimal information – i.e. 999 = 99.9 = 9.99
5 + (unit x 100)	Setpoint 1 High Control Limit	Strip decimal information – i.e. 999 = 99.9 = 9.99
6 + (unit x 100)	Setpoint 2 High Control Limit	Strip decimal information – i.e. 999 = 99.9 = 9.99
7 + (unit x 100)	Modulation Rate	0 = low fire 999 = high fire
8 – 20 + (unit x 100)	Reserved for future use.	

TROUBLESHOOTING CHECKLIST

Is the yellow PWR light on?

- NO - Check the power supply voltage is 7V to 35V and is to specification.

Is the red 1TX light flashing?

- NO - This light should flash all the time that the yellow PWR light is ON to indicate the converter is polling the Fireye Nexus bus. If it does not, that would indicate a fault with the unit. Try powering the unit off and on again.

Is the red 1RX light flashing?

- No - If any units are connected to the Fireye Nexus bus, this light should flash occasionally to indicate that the converter is receiving data. If it does not, check the wiring to the Fireye Nexus units. The terminals labeled 'TXA' and 'RXA' should be connected to the terminals labeled 'RS485 A', 'RS485 +' or 'RS485 A+' on the Fireye Nexus units. Similarly, the 'B' terminals should connect to 'B' or 'RS485-'. Do these units have communications options fitted (where appropriate)? Do they work with ComFire?
IF THE 1RX LIGHT IS CONSTANTLY ON, THE RS485 A / B LINES ALMOST CERTAINLY NEED TO BE SWAPPED.

Is the red 2RX light flashing?

- NO - This light should flash when the unit receives data from MODBUS. If it does not, check the wiring to the Modbus units. The terminals should be connected as detailed in the connections section – however on some equipment, the A / B terminals are incorrectly marked. IF THE 2RX LIGHT IS CONSTANTLY ON, THE RS485 A / B LINES ALMOST CERTAINLY NEED TO BE SWAPPED.

Is the red 2TX light flashing?

- NO - This light should flash when this unit transmits a message to Modbus. It will only do this in response to a request from the Modbus master, which may happen infrequently. Are the Modbus communications settings / slave address correct? Is the master actually polling this unit?



SPECIFICATIONS

Modbus Communications	110 to 115200 baud, none/odd/even parity, 1 or 2 stop bits, 7 or 8 data bits.
RS422/485 Interface	Receiver threshold 200mV typical (differential). Hysteresis 70mV typical. Receiver input impedance 12kW minimum. Transmitter output swing 0 to +5V (no DC load); +2V to +3V (120W load).
Power Supply	+7 to +35V DC. Input power is approximately constant at 1 to 2 watts. Start-up current may reach 600mA for a short period. At start-up, supply must reach 7V within 1 second.
Isolation	64V PK, tested at >1000V AC RMS, 1 second.
Environmental	Operating temperature 32 to +125F (0 to 50° C). Storage temperature – 76°F to 160°F (25 to 70° C). Relative humidity (operating and storage) 0 to 90%, noncondensing.
Ventilation	Rail-mounted KD485 must have 2" (50mm) gap above and below.
EMC Compliance	Emissions EN50081-2 (94), immunity EN50082 (95)
Dimensions	1.15" (29mm) (W) x 4.5" (114mm) (H) x 3.8" (97mm) (L) approx in rail mounted position, including screw terminals.

NOTICE

When Fireye products are combined with equipment manufactured by others and/or integrated into systems designed or manufactured by others, the Fireye warranty, as stated in its General Terms and Conditions of Sale, pertains only to the Fireye products and not to any other equipment or to the combined system or its overall performance.

WARRANTIES

FIREYE guarantees for *one year from the date of installation or 18 months from date of manufacture* of its products to replace, or, at its option, to repair any product or part thereof (except lamps, electronic tubes and photocells) which is found defective in material or workmanship or which otherwise fails to conform to the description of the product on the face of its sales order. **THE FOREGOING IS IN LIEU OF ALL OTHER WARRANTIES AND FIREYE MAKES NO WARRANTY OF MERCHANTABILITY OR ANY OTHER WARRANTY, EXPRESS OR IMPLIED.** Except as specifically stated in these general terms and conditions of sale, remedies with respect to any product or part number manufactured or sold by Fireye shall be limited exclusively to the right to replacement or repair as above provided. In no event shall Fireye be liable for consequential or special damages of any nature that may arise in connection with such product or part.



FIREYE™
3 Manchester Road
Derry, New Hampshire 03038 USA
www.fireye.com

NEX-3026
JUNE 21, 2006