

FLEXIBLE SINGLE TUBE IGNITER (FST)

THE FLEXIBLE SINGLE TUBE (FST) IGNITER IS A RELIABLE SOURCE OF IGNITION ENERGY FOR USE IN A TILTING TANGENTIAL TYPE BOILER. It is a Class I, continuous duty, igniter capable of burner ignition and low load support. It is easily installed in the auxiliary air nozzles between the main fuel elevations and is designed with flexible components to accommodate the tilting of the fuel nozzles. The FST Igniter is capable of burning liquid or gaseous fuels. With capacities up to 10% of boiler heat input, the FST improves boiler / turbine startup flexibility.

Each FST Igniter includes a flexible fuel gun, a flexible retractable High Energy Spark Igniter (HESI) and a flame detector with a flexible fiber optic assembly. The fuel gun has an air swirler at the furnace end which mixes the windbox air and fuel at the tip to create a stable flame. All major components are fixed to a burner front plate that is designed to match the existing bolt pattern at the burner front. All components are designed to freely tilt with the fuel nozzle through a $\pm 30^\circ$ angle. Flame detection is accomplished by the use of either an ultraviolet or infrared detector, depending on the fuel fired.

Optional equipment includes gun retraction, quick disconnect fuel and atomizing air couplings, as well as an electrical junction box.

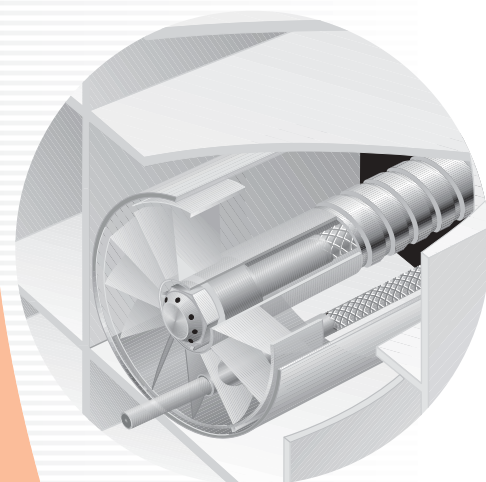

- **CLASS I IGNITER** – Capacities up to 37 MBTU/hr which will support ignition under all credible burner light-off or operating condition.
- **ONE FST IGNITER SUPPORTS TWO FUEL NOZZLES** – This arrangement results in half the number of igniters normally required.
- **FLAME STABILITY** – The stainless steel 7 1/2" air swirler creates a low pressure zone at the tip for stable flame operation.
- **LOW OPACITY** – The turbulent mixing of the fuel and combustion air caused by the swirler ensures low opacity during cold light-off.
- **EASY RETROFIT** – Can be installed between most fuel elevations with minimal or no burner modification.
- **RELIABLE IGNITION** – The High Energy Spark Igniter (HESI) automatically inserts to the most efficient light-off position for repeatable ignition.



Re-powering your world



IGNITERS



FLEXIBLE SINGLE TUBE IGNITER (FST)

SPECIFICATIONS

Fuel:	No. 2 Oil or Natural Gas
BTU Rating – Oil:	10 – 37 MBTU/hr
– Gas:	10 – 20 MBTU/hr
Fuel Pressure – Oil:	60 – 125 psig
– Gas:	12 – 25 psig
Cooling/Combustion Air	
Flow:	40 SCFM
Pressure:	6 WC
Guide Tube OD:	2.38"
Mount Tube OD:	2.88"
Length:	As Required, up to 8.5'
Atomizing Pressure:	20 psig
(Differential over oil pressure)	
Material of Construction:	Guide Tube and Mount Tube, Carbon Steel; Guide Tube Tip and Pilot Area, 304 SST
Retract Cylinder Air Pressure:	60 to 100 psig
(HESI/oil gun)	

HESI SPECIFICATIONS

Input Voltage:	120 – 240VAC, 50/60 Hz
Output Energy:	12 joules per spark
Output Voltage:	2000 VDC
Spark Rate:	3 per second
Duty Cycle:	100% at temp –18°C to 57°C (0°F to 135°F)

